

2023
3RD AND GREEN RECONSTRUCTION
CITY OF YANKTON, SD
CITY PROJECT NO. 2023-011

REGION NO.	STATE OF	PROJECT	SHEET NO.	TOTAL SHEETS
8	S.D.	2023-011	1	39
COVER				

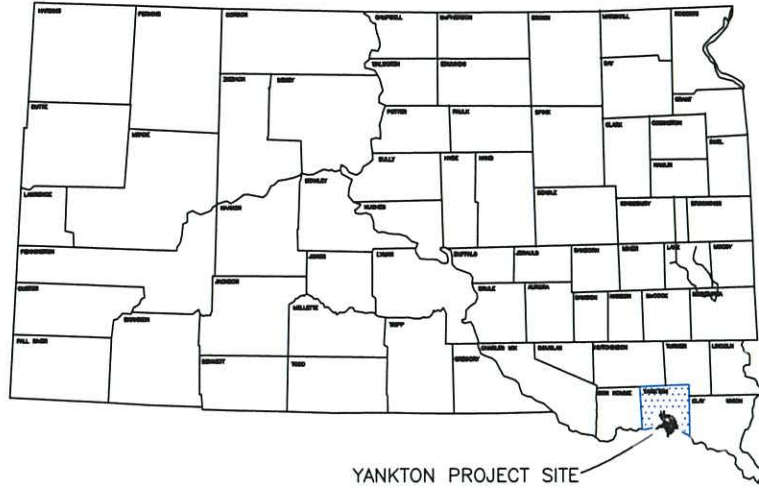

YANKTON PROJECT SITE

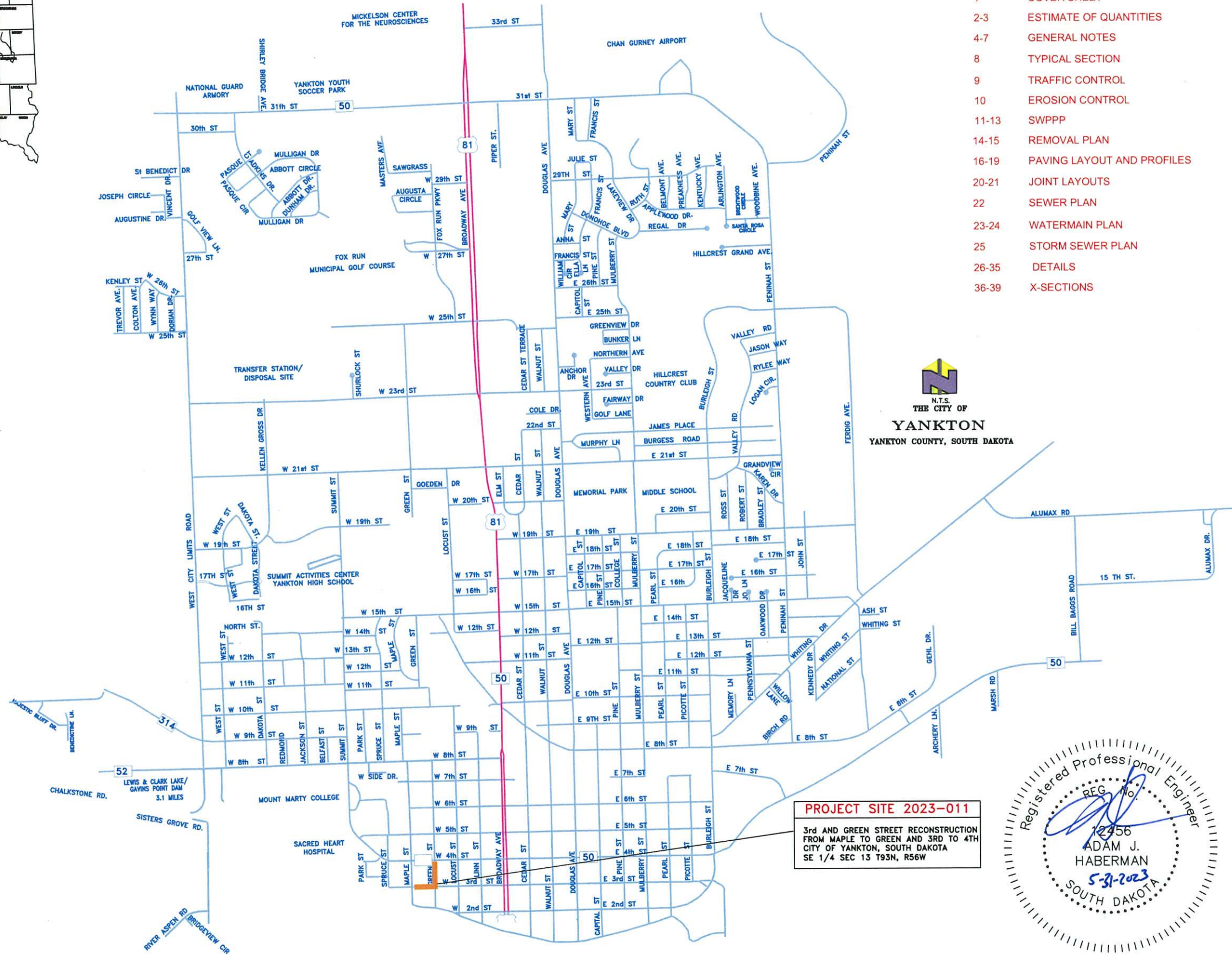

INDEX OF SHEETS

- 1 COVER SHEET
- 2-3 ESTIMATE OF QUANTITIES
- 4-7 GENERAL NOTES
- 8 TYPICAL SECTION
- 9 TRAFFIC CONTROL
- 10 EROSION CONTROL
- 11-13 SWPPP
- 14-15 REMOVAL PLAN
- 16-19 PAVING LAYOUT AND PROFILES
- 20-21 JOINT LAYOUTS
- 22 SEWER PLAN
- 23-24 WATERMAIN PLAN
- 25 STORM SEWER PLAN
- 26-35 DETAILS
- 36-39 X-SECTIONS

LEGEND

- POWER POLE
- TELEPHONE BOX
- CURB INLET
- SANITARY SEWER MANHOLE
- STORM SEWER MANHOLE
- EXISTING VALVE
- EXISTING FIRE HYDRANT
- PROPERTY LINE
- SANITARY SEWER
- STREET CENTERLINE
- CURB
- WATER
- BURIED CABLE TV
- BURIED GAS LINE
- BURIED ELECTRIC LINE
- BURIED TELEPHONE LINE
- EXISTING STORM SEWER

PROJECT SITE 2023-011

3rd AND GREEN STREET RECONSTRUCTION
 FROM MAPLE TO GREEN AND 3RD TO 4TH
 CITY OF YANKTON, SOUTH DAKOTA
 SE 1/4 SEC 13 T93N, R56W

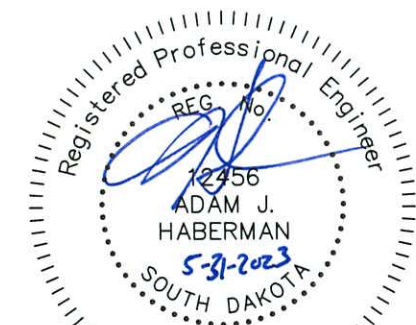

ESTIMATE OF QUANTITIES

BID ITEM	DESCRIPTION	BID QUANTITY	UNIT	BID ITEM	DESCRIPTION	BID QUANTITY	UNIT
GENERAL				WATERMAIN			
1	MOBILIZATION	1	LS	28	6" PVC WATERMAIN C-900	846	LF
TRAFFIC CONTROL				29	1" CURB STOP AND BOX	13	EA
2	TRAFFIC CONTROL	708	UNITS	30	1" COPPER SERVICE LINE	592	LF
3	TRAFFIC CONTROL MISC	1	LS	31	6" MJ 90 DEGREE BEND	1	EA
REMOVALS				32	6" MJ TEE	2	EA
4	SAW EXISTING CONCRETE	250	LF	33	6" MJ CAP	1	EA
5	REMOVAL OF CONCRETE PAVEMENT	3448	SY	34	6" MJ GATE VALVE WITH BOX	3	EA
6	REMOVAL OF CURB AND GUTTER	50	LF	35	6" MEGALUGS	25	EA
7	UNCLASSIFIED EXCAVATION	1	LS	36	6" X 45 DEGREE MJ BEND	2	EA
8	UNDERCUTTING	50	CY	37	6" MJ OVERSIZED SLEEVE	1	EA
9	WATER FOR EMBK. OR GRAN. MATRL.	10	KGAL	38	6" MJ SLEEVE	3	EA
EROSION CONTROL				39	GRANULAR MATERIAL FOR WATERMAIN	846	LF
10	TOPSOIL	1	LS	40	INSTALL TEMPORARY FIRE HYDRANT	2	EA
11	SEEDING	1	LS	41	CUT AND TIE INTO EXISTING WATERMAIN	4	EA
12	VEHICLE TRACKING CONTROL	1	EA	42	CONNECT WATER SERVICE LINES	13	EA
13	INLET SEDIMENT CONTROL	4	EA	SURFACING			
14	SILT FENCE	60	LF	43	6" PCCP PAVEMENT	2473	SY
15	GEOTEXTILE FABRIC	400	SY	44	CONCRETE C & G TYPE B66	1582	LF
SANITARY SEWER				45	6" APPROACH PAVEMENT	3278	SF
16	REMOVAL OF SAN. SEWER LINE	423	LF	46	4" SIDEWALK	1446	SF
17	8" PVC SANITARY SEWER MAIN 8'-10'	180	LF	47	6" SIDEWALK	128	SF
18	8" PVC SANITARY SEWER MAIN 10'-12'	273	LF	48	AGGREGATE BASE COURSE	2638	SY
19	48" SANITARY SEWER MH	4	EA	49	DRILL BARS INTO EXISTING PAVEMENT	45	EA
20	RECONNECT SANITARY SEWER SERVICE	3	EA	50	DETECTABLE WARNING PANELS	60	SF
21	SANITARY SEWER SERVICE REPAIR	4	EA	51	6" FILLET SECTION	512	SF
22	GRANULAR MATERIAL FOR SEWER MAIN	453	LF	STORM SEWER			
23	2X3 TYPE B INLET	5	EA				
24	4X4 SS JUNCT. BOX	3	EA				
25	F&I 18" RCP CLIII	491	LF				
26	REMOVAL OF EXISTING PIPE	486	LF				
27	REMOVAL OF MH/JB/DI	8	EA				

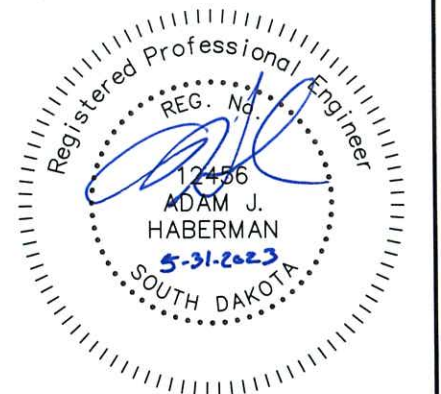

TABLE OF REMOVE AND REPLACEMENT OF CONCRETE SIDEWALK

LOCATION 3RD ST	REMOVE(SY)	REPLACE (SF)
0+09 ON 3RD ST (W) END	37	37(SY) 6" PCCP
0+90 LT.	3.9	35
1+33 LT	1.7	16
1+69 LT (ALLEY SW)	14.2	128 OF 6"
2+54 LT	3.4	30
3+63 LT (NW COR. 3RD)	13.6	129 (12 SF DWP)
4+22 LT (NE COR. 3RD)	31.8	308 (24 SF DWP)
4+26 RT (SE COR. 3RD)	33.6	298 (24 SF DWP)
		37 SY (TOTAL 6" PCCP)
SW THRU DRIVEWAYS/ALLEYS 6"		128 (TOTAL 6")
		816 (TOTAL 4")
TOTAL	139	944 SF 60 SF DWP

TABLE OF DROP INLETS AND JUNCTION BOXES

LOCATION	TYPE	QUANTITY
3+45 LT. & RT. (3RD ST)	B	2
3+45 RT.. (3RD ST)	JCT. 4X4	1
3+71 RT. (GREEN ST)	B	1
3+84 RT.(3RD ST)	JCT. 4X4	1
1+40 LT & RT RT. (GREEN ST.)	B	2
1+40 LT. (GREEM ST)	JCT. 4X4	1

TABLE OF REMOVE AND REPLACE SAN. SEWER MH AND CASTINGS

LOCATION	QUANTITY
MH#1 0+06 - 8.6' LT (3RD ST.)	1
MH#2 1+79 - 8.9' LT (3RD ST.)	1
1+79 - 40.6' LT REMOVE EXISTING (3RD ST.)	1
3+73 - 4.7' RT REMOVE EXISTING (3RD ST.)	1
MH#4 3+73 - 4.6' LT (3RD ST.)	1
3+80 - 8.7' LT. REMOVE EXISTING (3RD ST)	1
MH#3 4+24 - 9.5' LT (3RD ST.)	1

TABLE OF REMOVE AND REPLACEMENT OF CONCRETE APPROACH PAVEMENT

LOCATION 3RD ST	REMOVE(SY)	REPLACE (SF)
1+80 LT.(ALLEY)	39	375
3+59 RT	49	372
LOCATION GREEN ST	REMOVE(SY)	REPLACE (SF)
1+82 LT.	91	804
1+90 RT.	28.2	269
2+78 LT.	28.3	255
2+79 RT.	16.6	161
3+73 LT.	0	337
4+16 RT.	53	489
4+57 LT.	24.3	216
TOTAL	291	3278

TABLE OF REMOVE AND REPLACEMENT OF CONCRETE SIDEWALK

LOCATION GREEN ST	REMOVE(SY)	REPLACE (SF)
1+62 RT.	2.6	24
1+67 RT.	9.4	82
2+03 RT.	2.6	24
2+16 RT.	6.8	61.2
2+35 LT	3.4	29
2+40 RT.	2.6	24
2+50 LT.	2.6	24
2+57 RT.	2.7	25
2+54 LT	3.4	30
3+12 RT.	2.6	24
3+25 RT.	2.6	24
3+32 LT.	4.0	36
3+45 RT.	3.0	27
3+46 LT.	2.0	17
3+87 RT.	6.4	58
3+99 LT.	4.0	36
4+04 RT.	2.6	24
4+30 RT.	2.6	24
4+74 LT.	4.0	36
		630 (TOTAL 4")
TOTAL	70	630 SF

TABLE OF 6" PCC FILLET SECTION REMOVAL AND REPLACE

STATION TO STATION	RADIUS	REMOVAL SY	REPLACE (SF)
NW COR. 3RD AND GREEN	15'		129
NE COR. 3RD AND GREEN	15'		130
SW COR. 3RD AND GREEN	15'		128
SE COR. 3RD AND GREEN	15'		125
TOTAL			512 SF

JOB CONTROL	
CP 2	N 209648.9890 E 2754209.6810 ELEV. 1219.220
CP 3	N 209421.5370 E 2754175.5000 ELEV. 1221.32
CP 41	N 209456.7170 E 2753910.0240 ELEV. 1231.704
CP 55	N 209469.6550 E 2753860.0730 ELEV. 1234.104

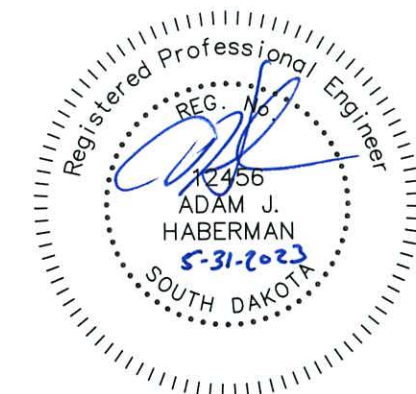

REGION NO.	STATE OF	PROJECT	SHEET NO.	TOTAL SHEETS
8	S.D.	2023-011	4	39
NOTES				

GENERAL NOTES

SPECIFICATIONS TO BE USED

City of Yankton Standard Specifications and the Standard Specifications for Roads and Bridges 2015 Edition and Required Provisions, Supplemental Specifications, and/or Special Provisions as included in the Proposal.

UTILITIES

Location and protection of all underground utilities is the Contractor's responsibility. The Contractor will be required to coordinate work with the utility companies. Existing utilities and service lines that coincide with proposed underground main locations are to be located in advance by the contractor such that proposed underground mains can be adjusted to avoid conflict.

Utility locations are coordinated by calling: 1-800-781-7474 (One Call)

SEQUENCE OF OPERATIONS

The Contractor shall use the following sequence of operations that are listed on the traffic control sheets unless an alternate is approved by the Engineer. An alternate sequence must be submitted in writing a minimum of one week prior to the preconstruction meeting.

All trenches are to be backfilled, compacted and covered with service gravel on the same day the pipe is laid. Aggregate Base Course will be used in lieu of Service Gravel as directed by the engineer to temporarily re-open portions of streets after the pavement is removed.

Contractor to start on 3rd street and have all underground utilities installed and Aggregate Base Course in place before proceed north on Green St

ACCEPTANCE TESTING

The City will be responsible for taking the first acceptance test and a backup test if required. All subsequent tests required due to failures will be paid by the Contractor by deducting the cost from the pay request.

INCIDENTAL WORK

All salvageable materials shall be taken out intact and stockpiled within the right-of-way to the satisfaction of the Engineer. The Contractor shall perform salvage operations in a manner that will prevent damage to the salvageable materials.

Salvable materials will be picked up by the City.

All concrete removed from the existing structures and other disposable material shall be disposed of in accordance with the Waste Disposal Site note.

OCCUPYING STATE ROW

Contractor shall comply with Traffic Control Standards under SD DOT Standard Specifications for Roads and Bridges, and as per the manual on Uniform Traffic Control Devices.

STREET SWEEPING

The Contractor shall be responsible to maintain a clean and well-kept work site. Adjacent streets shall be swept clean of construction debris at the Engineer's request. Street sweeping shall be considered incidental to the project. No separate payment will be made.

TRAFFIC CONTROL NOTES

GENERAL MAINTENANCE OF TRAFFIC

1. Storage of vehicles and equipment shall be as near the right-of-way as possible. Contractor's employees should mobilize at a location off the right-of-way and arrive at the work sites in a minimum number of vehicles necessary to perform the work. Indiscriminate driving and parking of vehicles within the right-of-way will not be permitted. Any damage to the vegetation, surfacing, embankment, delineators and existing signs resulting from such indiscriminate use shall be repaired and/or restored by the Contractor, at no expense to the City, and to the satisfaction of the Engineer.

2. The Contractor shall designate an employee whose responsibility is the maintenance of traffic, 24 hours a day and 7 days a week. The person so designated must have training and experience in the field of construction traffic control and be knowledgeable about the Manual on Uniform Traffic Control Devices (MUTCD). The cost of the traffic control person shall be incidental to the contract lump sum price for Traffic Control Miscellaneous. The employee selected must be approved by the Engineer. The name, phone number, and location of person(s) shall be provided to the county sheriff's department and the local police department. Road closure and barricading shall immediately be reported to the local police department by the Contractor. Local police department phone number 605-668-5210

3. Work activities during non-daylight hours are subject to prior approval.

4. The contractor shall maintain traffic control every day. The contractor shall have \$200.00 per day deducted from the contract for each day that traffic control is not maintained. If traffic control is not in place when the contractor begins work which requires traffic control, payment for bid item "Traffic Control" will be reduced by 50%.

5. The Contractor shall notify the City of Yankton Street Department prior to construction to enable the city forces to remove and salvage existing traffic control signs. City of Yankton Street Dept. number 605-668-5211

PEDESTRIAN TRAFFIC

The Contractor will be required to maintain pedestrian access during construction. Pedestrian access shall be ADA accessible and shall conform to the Manual on Uniform Traffic Control Devices 2009 edition. Access can either be maintained on concrete sidewalk or on a temporary boardwalk. This work may include but is not limited to sawing existing sidewalk to leave half in place, staging sidewalk removal and construction to maintain access, installing safety fence around work areas, and construction and removal of temporary boardwalk. The Contractor shall determine the actual location of temporary access during construction and shall be approved by the Engineer. Payment for all work and associated materials shall be incidental to the contract lump sum price for "Traffic Control Miscellaneous".

TRUCK ROUTES

The Contractor shall only haul materials in and out of the construction site on the streets shown in the traffic control plans. All fully loaded trucks delivering materials or hauling out removals shall only utilize the streets labeled as "Primary Haul Route." Empty or lightly loaded trucks may utilize "Secondary Haul Route" with the permission of the Engineer.

EROSION CONTROL NOTES

DEWATERING AND EROSION CONTROL

Pumping required for the removal of surface water from the work area and/or depressions will be considered incidental to other pay items and not paid for separately. The Contractor shall be responsible for obtaining the required erosion control permits from the South Dakota Department of Environment and Natural Resources.

SITE MAINTENANCE

The Contractor is to keep the project site properly maintained and graded to drain storm water. No standing water is permitted on site. A penalty of \$500/day will be assessed each day standing water is not removed from site. All regulations pertaining to Storm Water Pollution Prevention will be enforced. Direct discharge of storm water into the storm sewer system is not acceptable.

EROSION CONTROL - VEHICLE TRACKING CONTROL

1. CONSTRUCTION

The work covered by this section consists of furnishing all labor and equipment and the performance of all operations in connection with the construction of temporary vehicle tracking control on the project, complete and in accordance with the plans and standard plates. The Contractor shall be responsible for accomplishing the required construction work on this project in such a manner as to effectively minimize and control water pollution which might be caused by vehicular tracking of soil. It is intended that these features be maintained in appropriate functional condition whenever vehicles come or go from the construction site where there is dirt exposed.

In addition to the details shown in the plans, other provisions for controlling erosion may be incorporated.

2. MATERIALS

1 1/2" to 3" rock shall be used. .

3. LABOR AND EQUIPMENT

All necessary labor and equipment shall be supplied to clean up any dirt or gravel off of the paved roadway surfaces at the end of each day. The contractor shall also remove any service gravel that has dirt mixed in with it from the project site when the tracking control is no longer necessary. Clean service gravel can be incorporated into the base material for the roadbed.

4. PAYMENT

Service gravel shall be paid for at the unit price bid in the contract for service gravel. Unit price for "Temporary Vehicle Tracking Control" shall be the amount paid for each site where the engineer requires the use of the temporary vehicle tracking control for however long it is needed. The Contractor will be charged \$50.00 for each day that dirt is not cleaned off of the street after it is placed or tracked onto the pavement.

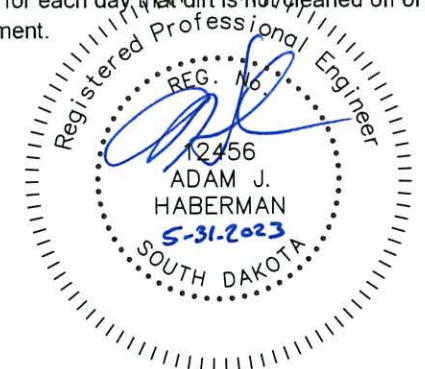

REGION NO.	STATE OF	PROJECT	SHEET NO.	TOTAL SHEETS
8	S.D.	2023-011	5	39
NOTES				

EROSION CONTROL - SILT FENCE NOTES

1. CONSTRUCTION

The work covered by this section consists of furnishing all labor and equipment and the performance of all operations in connection with the construction, maintenance and removal of the silt fence for the control of siltation on the project, complete and in accordance with the plans and standard plates. The Contractor shall be responsible for accomplishing the required construction work on this project in such a manner as to effectively minimize and control water pollution which might be caused by soil erosion from the project. It is intended that these features be maintained in appropriate functional condition from initial construction stages to final completion of the project.

After rainfall events, the Contractor shall take all necessary precautions to prevent silt from being carried away from the project site when water is being pumped out of any area where water is backed up on the project site

In addition to the details shown in the plans, other provisions for controlling erosion may be incorporated.

2. MATERIALS

A. Steel Fence Posts

The steel line posts for field fence shall have a cross section of one and one-half inches by one and one-half inches. The average weight shall be less than 1.33 pounds per linear foot. Paint for steel fence posts shall be the manufacturers standard paint finish.

B. Silt Fabric

The approved brands of engineering fabrics for silt fence are listed below:

Manufacturer/Distributor	Brand Name
Amoco Fabrics & Fibers Co.	Silt Stop
Carthag Mills	FX-325
Linq Industries Fabrics	GTF 400 EO
Mirafi Division of Nocolon	700 XG
Weblec, Inc.	Econofence with netting

3. BACKFILL

All compaction of backfill shall be accomplished with a mechanical tamper or pneumatic tamper. All compacting equipment shall be operated according to the manufacturers recommendations.

4. PAYMENT

Payment shall be based on the lineal foot of silt fence satisfactorily constructed and measured from outside of the end posts. The work completed in accordance with the plans and specifications at the applicable contract price in the bid schedule which price shall constitute full compensation for furnishing all materials, equipment, labor, and tools necessary for completion of the work. The unit price shall also include removing muck from behind the silt fence after rain events and removing the silt fence when it is no longer needed.

INLET SEDIMENT CONTROL Refer to Standard Plates 734.10 SD DOT AND SIOUX FALLS 734.16 - Drop inlet sediment filters.

REMOVAL NOTES

GENERAL NOTES

The Contractor will be required to raze, remove and dispose of all buildings and foundations, structures, fences, advertising signs, and other obstructions of which any portion are on the right-of-way or Temporary Easements except Utilities and those for which other provisions have been made for removal, in accordance with Section 110 of the Standard Specifications.

The removal and disposal of all buildings, foundations and other obstructions not removed under Incidental Work or on a unit basis shall be considered as subsidiary work to the other Contract Items and no separate payment will be made for their removal and disposal.

REMOVAL OF EXISTING CONCRETE PAVEMENT

Payment for concrete removal is included in the contract unit price per square yard for "Removal of Concrete Pavement". Payment shall be at the contract unit price per square yard, regardless of variations in thickness. Joints shall be sawed wherever existing concrete is to be connected to new construction.

When asphalt is laid over concrete pavement, removal of the asphalt surfacing shall be incidental to the unit price for "Removal of Concrete Pavement".

REMOVAL OF EXISTING ASPHALT PAVEMENT

Payment for asphalt mat removal is included in the contract unit price per square yard for "Removal of Asphalt Concrete". Payment shall be at the contract unit price per square yard, regardless of variations in thickness.

WASTE DISPOSAL SITE

Contractor shall dispose of broken concrete and asphalt generated by this project at the city stockpile site located at 23rd and Kellen Gross Drive. No tipping fee will be assessed to Contractor for broken concrete and asphalt disposed of at this site Concrete and asphalt is to be kept separate from earth material during the removal process. Concrete and asphalt may be mixed.

Asphalt contaminated with soil during the removal process or concrete containing reinforcing steel or contaminated with soil must be disposed of at the Yankton rubble site, 23rd and Kellen Gross Drive. Disposal fees shall be the Contractors responsibility, and considered incidental to other pay items.

The Contractor will be required to use a state permitted solid waste disposal facility. The Contractor can obtain a list of permitted solid waste disposal facilities in the Yankton area or discuss proper disposal of construction and demolition debris by contacting Waste Management Program at 1-(605)-773-3153.

Construction/demolition debris may not be disposed of within the ROW.

UNCLASSIFIED EXCAVATION

Unclassified Excavation will be paid for on a lump sum basis. The bid item for "Unclassified Excavation" shall include removing the existing material to a depth of 12 inches below the new road surface shown on the typical sections. Estimated quantities in cubic yards are shown below. These estimates are based on the assumption of 2 inches of existing Asphalt Pavement on top of 4 1/2" of concrete being removed separately. It will be the Contractor's responsibility to find a location for the existing subgrade material, that needs to be removed.

Estimate of 1100 cu yds. of removal on 3rd and Green St.

UTILITY NOTES

GENERAL ITEMS

All existing pipe and material removed by the contractor shall be appropriately disposed of by the contractor. All open ends of abandoned in place piping shall be plugged with concrete unless otherwise noted in plans. All abandoned valve boxes shall be removed to at least 2 feet below the ground surface and filled with granular material.

Salvageable material shall become the property of the City of Yankton, as directed by engineer. Abandoned valves shall have the valve boxes removed to a depth of not less than 2 feet below ground level. Removal of water main, valves and fittings, necessary for the construction of the new items, shall be incidental to other project costs.

STRUCTURE REMOVAL

The removal of existing pipe and manholes is to include the plugging of existing pipe if necessary with concrete and the removal of the structure. Castings and manhole covers removed are to be delivered to the city street shop.

WATER MAIN GENERAL

The contractor shall provide new water main with a minimum of 6' of cover. The water main will be AWWA C-900. Adjust the depth of the new main to match existing main where connections to existing mains are shown on plans. Existing copper services will be connected to the new water main. Services will be replaced if line is galvanized, lead or smaller than 3/4 inch copper. Replace these service lines to ROW line behind new curb & gutter or as directed by engineer with 1 inch copper and install a new curb stop and box. Services may be "hole hogged" with an underground piercing tool at no additional expense to the City of Yankton.

Contractor shall backfill all open trenches to the end of the pipe every night and appropriately protect the open hole with fencing. The Contractor shall have \$200 per day deducted from the contract for each day that this is not done.

The City to supply fire hydrants for the project.

PVC WATER MAIN ENCASEMENT PIPE

PVC Water Main Encasement Pipe shall be installed at the locations shown on the plans and at locations determined by the Engineer on the project.

PVC Water Main Encasement Pipe shall be of water main quality, including joints, and be either ASTM D2241, Class 160 or Class 125 or AWWA C900 DR 25 or DR 18.

All costs for installation of the new water main in the encasement pipe, attachment of skids to the new water main, and casing seals at the ends of the encasement pipe shall be incidental to the contract price per foot for PVC Water Main Encasement Pipe.

CUT AND TIE TO EXISTING WATER MAIN

Where "Cut and Tie to Existing Water Main" is required, Contractor shall make the required connection at a time to be designated by the City. Where the new main is to be connected to existing mains, the connection, sawing, pumping of water, labor and other items necessary to complete the tie are considered to be part of the bid item. This time may be during nighttime hours. The exact time will vary from location to location, to accommodate the needs of water users who will experience an outage. All costs associated with work during this time period shall be incidental to the contract price per each for "Cut and Tie to Existing Water Main".

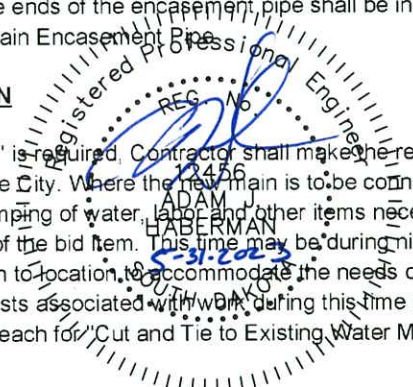

REGION NO.	STATE OF	PROJECT	SHEET NO.	TOTAL SHEETS
8	S.D.	2023-011	6	39
NOTES				

POLYETHYLENE ENCASUREMENT

All valves, fittings, and other ductile iron appurtenances and pipe are to be wrapped with 8 mil. thick polyethylene in accordance with AWWA C-105. This work is incidental to other pay items.

SLEEVES AND RETAINER GLANDS

The contractor shall furnish and install all clamps, ready rods, blocking and cradling necessary for the project as an incidental project cost.

Retainer glands are to be installed in addition to blocking at all fittings (mega lug series 2000pv). Retainer glands and sleeves will be paid for per each at the bid unit price.

VALVE BOX CENTERING ADAPTER

All valve boxes shall be equipped with a rubber boot/sleeve that covers and firmly holds the bottom of the valve box over the valve nut (valve box adapter ii).

TRACER WIRE SYSTEM

The tracer wire system shall be installed with ductile iron water mains and with PVC water mains to the satisfaction of the engineer.

Tracer wire shall be no. 12 solid single strand Type TW or THHn, or approved equal.

The conductor shall be solid or stranded copper per ASTM B-1, B-3, or B-8. The ground rod shall be a 3/8-inch diameter, 60-inch long steel rod uniformly coated with metallicly bonded electrolytic copper. Blackburn catalog no. 3755, or equal. The ground rod at the fire hydrant shall be of the same material except that the ground rod shall be 30 inches long.

Ground rod clamps shall be high strength, corrosion resistant copper alloy. Blackburn catalog no. G3, or equal.

Splice kits shall be Scotchlok DBY-Y connectors or equal.

The cost of the tracer wire system is considered to be a part of the cost of the water main installation.

TRACER WIRE INSTALLATION

Tracer wire shall be installed with PVC and ductile iron water mains. The wire shall be installed along the lower quadrant of the pipe, but the pipe shall not be laid directly on the wire. Ground rods shall be installed adjacent to connections to existing piping and in the locations specified on the plans. The tracer wire shall be brought to each fire hydrant and connected to a 30" ground rod that extends up to the bolted flange just above the ground surface or a minimum distance of 3" above the ground surface. The ground rod shall be taped to the fire hydrant barrel in at least four locations below the ground surface. The tracer wire shall be spliced only if approved by the engineer and all underground splices shall be inspected by the engineer prior to backfilling. The tracer wire system is considered to be a part of the price bid for water mains.

The contractor shall be responsible for testing the tracer wire system for conductivity. Testing for conductivity shall be completed prior to finish surfacing activities. If the tracer wire does not function as intended, the contractor shall repair the system to the satisfaction of the engineer and the City will charge \$50 per hour to retest the system with a minimum charge of \$50.

DISINFECTION, TESTING, AND OPERATION OF NEW MAIN

New water main shall be disinfected, have two passing bacteriological tests, at least 24 hours apart, and be pressure tested before the water main is put into service. The city will take the

test sample and the contractor shall furnish a service line or other suitable location on the new pipe at which a sample can be collected. The contractor shall furnish the equipment necessary for the pressure test and shall conduct the test in the presence of someone from the City Engineering Department staff. New mains shall be installed and disinfected before any of the service lines are reconnected from the old main to the new main. New mains will not be put into operation without city approval.

SANITARY SEWER

MANHOLE EXTERNAL FRAME SEAL

The furnishing and installing of the manhole frame seal shall be paid for under replace and adjust manhole rim and cover bid item. Full compensation for furnishing and installing of the complete manhole frame seal and all appurtenances necessary for the proper installation of the manhole frame seal for the manhole. (See section 210 of the City of Yankton standard specifications for sanitary sewer mains, service lines and appurtenances for approved products list.)

MANHOLE EXTERNAL JOINT SEALS

Manhole external joints seals, meeting the requirements of ASTM C877 Type III, shall be used on all manhole joints unless otherwise specified. Manhole external joint seals shall be Infi-Shield Gator Wrap as manufactured by Sealing Systems Inc., WrapidSeal as manufactured by CANUSA-CPS, or an approved equal. The external joint seal materials shall be compatible with City of Sioux Falls Standard 48 inch diameter RCP manholes and shall be a minimum of 9 inches wide.

Manhole external joint seals shall be considered incidental per manhole regardless of depth or number of joints.

PAVING & RESTORATION NOTES

GEOTEXTILE FABRIC FOR SUBGRADE STABILIZATION

Geotextile fabric shall be installed at locations designated by the engineer underneath the granular base course. The bid item GEOTEXTILE FABRIC has been established to pay for all labor, equipment and material to install the fabric.

Pay quantities for the geotextiles will be paid for at the contract price per square yard in place. Measurement for payment excludes the geotextile used for overlapping as well as seam overlaps. Installation shall be in accordance with the manufacturer's recommendations. Overlap shall be a minimum of 24". The end of the roll shall overlaps shall be 3' min.

The contractor shall not drive equipment directly on top of the geotextile. Should the geotextile be torn or punctured, the damaged area shall be repaired or replaced by the contractor at no expense to the owner. The repair shall consist of a patch of the same type of geotextile a minimum of 3' from the edge of any part of the damaged area. Geotextile fabric shall conform to the requirements listed below. The contractor shall provide a certificate of compliance verifying that the material meets the specification prior to the installation of the fabric.

1. Wide Width Tensile Strength (ASTM D-4595) 3600lb/ft min.
2. Wide Width Tensile Strength at 5% Strain (ASTM D-4595) 1350 lb/ft min.
3. Permittivity (ASTM D-4491) 0.25 sec-1 min.
4. UV Resistance at 500 hours (ASTM D-4355) 70% min.

The City has verified that the following products meet these specifications.

1. Mirafi HP370
2. Propex Getotex 3x3
3. Lumite GTF465

AGGREGATE BASE COURSE

Aggregate Base Course will be supplied by the City of Yankton. Material can be obtained at City stockpile site located at 23rd and Kellen Gross Dr. This material is to be weighed before leaving landfill. The Contractor is to supply his own personnel and equipment to load trucks. Landfill hours are from 8am to 3:45pm. This material to be used under all newly placed concrete /asphalt and to maintain access to intersecting streets and driveways as needed. Unit price shall constitute full compensation for personnel and equipment to load, haul, and place material. Aggregate Base Course shall be compacted to 95% of standard proctor density.

SURFACING THICKNESS DIMENSIONS

Except as hereinafter set forth, plans square yards will be applied even though the thickness may vary from that shown on the plans.

At those locations where material must be placed to achieve a required elevation, plans square yards will not be varied to achieve the required elevation.

"6" NONREINFORCED CONCRETE PAVEMENT

The Coarse Aggregate shall be Crushed Ledge Rock.

The fine aggregates may require screening as determined by the Engineer.

The concrete for the nonreinforced PCC shall be of an approved job mix. The mix design shall be submitted three weeks prior to and approved prior to any concrete placement. The design mix shall meet a minimum 4000 PSI compressive strength in 28 days.

Concrete used in Portland cement concrete pavement shall have a minimum cementitious material content of 600 pounds per cubic yard, with a fly ash content of 25%. Any variations must be approved in writing by the Engineer prior to any concrete placement. Fly ash shall be class F and shall meet the requirements of Section 605 of the SDDOT Standard Specifications for Roads and Bridges. The maximum allowable water/cement ratio shall be 0.42.

In lieu of an automatic grader operating from a preset line, a motor grader or other suitable equipment may be used to bring the base course to final grade prior to placement of the concrete.

A construction joint shall be sawed whenever new concrete pavement is placed adjacent to existing concrete pavement.

There will be no direct payment for trimming of the Base Course for PCC pavement. The trimming will be considered incidental to the related items required for PCC pavement. Trimming shall be performed as required by Section 380.3c of the Standard Specifications.

An automated paving machine such as a Bidwell, or equivalent shall be required for main line paving. An air or vibratory screed will not be allowed for main line paving.

Joints to be sealed shall be thoroughly sandblasted, clean and dry as required by Section 380 P.

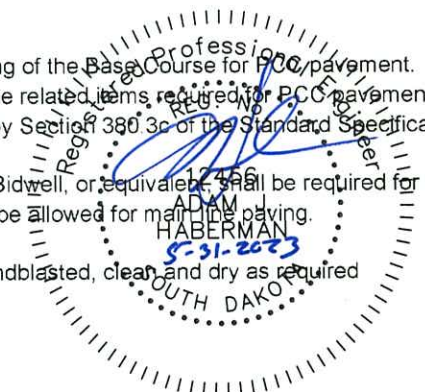

REGION NO.	STATE OF	PROJECT	SHEET NO.	TOTAL SHEETS
8	S.D.	2023-011	7	39
NOTES				

MANHOLE ADJUSTMENT

All costs for adjustment of the sewer manhole frame and lid to finished grade including removal and repair upper courses of brick or concrete, grouting, water-proofing and adjustment rings shall be incidental to the contract unit price per each for "Adjust Manhole" All existing rims & covers will be replaced with Neenah R1733 frame and lid. The lids shall contain concealed pick holes and be equipped with a gasketed self-sealing type covers.

STEEL BAR INSTALLATION

The Contractor shall install Steel No. 9x18" epoxy coated deformed tie bars into drilled holes in the existing concrete pavement. An epoxy resin adhesive must be used to anchor steel bars in the drilled holes.

The steel bars shall be cut at the specified length by sawing and shall be free from burring or other deformations. Shearing will not be permitted.

Epoxy resin adhesive shall be of the type intended for horizontal applications, and shall conform to the requirements of ASTM C 881, Type 1, Grade 3 (equivalent to AASHTO M235, Type 1, Grade 3).

The diameter of the drilled holes in the existing concrete pavement for the steel bars shall not be less than 1/8 inch nor more than 3/8 inch greater than the overall diameter of the steel bar. Holes drilled into the existing concrete pavement shall be located at mid-depth of the slab and true and normal. The drilled holes shall be blown out with compressed air using a device that will reach to the back of the hole to ensure that all debris or loose material has been removed prior to epoxy injection.

Mix the epoxy resin as recommended by the manufacturer and apply by an injection method approved by the Engineer. If an epoxy pump is utilized, it shall be capable of metering the components at the manufacturers designated rate and be equipped with an automatic shut-off. The pump shall shut off when any of the components are not being metered at the designated rate. Fill the drilled holes 1/3 to 1/2 full of epoxy, or as recommended by the manufacturer, prior to insertion of the steel bar. Care shall be taken to prevent epoxy from running out of the horizontal holes prior to steel bar insertion. Rotate the steel bar during installation to eliminate voids and ensure complete bonding of the bar. Insertion of the bars by the dipping method will not be allowed.

Cost for the epoxy resin adhesive, steel bars, drilling of holes, applying the adhesives, installing the steel bars into the drilled holes and all other items incidental to the installation of the steel bars shall be included in the contract unit price per each for "Install Steel Bar in Concrete Pavement".

Steel bars shall be installed at the following locations:

LOCATION	#5 BARS EACH
0+00 (3 RD WEST)	12
4+40 (3 RD EAST)	13
4-84 (GREEN NORTH)	20

CONCRETE SIDEWALK

Concrete sidewalk shall be constructed in accordance with Section 651 of Standard Specifications. Base Course material, two (2) inches thick, shall be placed beneath the sidewalk.

CURING OF CONCRETE

Portland Cement Concrete Pavement, Concrete Curb & Gutter, Sidewalks, Valley Gutters, and Fillets shall be cured. All concrete shall be cured in accordance with section 380.3.P2 of the 2015 SDDOT Standard Specifications for Roads and Bridges except as modified in this note. All concrete shall be cured with a White Pigmented Linseed Oil Base Emulsion Compound when cured using the Impervious Membrane Method. Curing compound material shall be in accordance with section 821.1.D.

CONCRETE JOINT SEALER

Concrete Joint Sealer shall be hot poured elastic joint sealer and shall conform to section 870 of the Standard Specifications. Payment for concrete joint sealer shall be incidental to PCC Pavement and no separate payment shall be made.

DETECTABLE WARNING PANEL

In order to comply with the Americans with Disabilities Act (ADA), detectable warning panels are to be placed at locations designated in the plan set. Detectable Warnings consist of a composite or polymer type of panel and should be installed into wet concrete. Surface applied products that are applied to cured concrete are not allowed. The detectable warnings shall be a brick red color for application in concrete curb ramps.

Current detectable warning panels approved for use and installation within the public right of way are:

Product	Manufacturer
Armor Tile Modular Paver Series	Engineered Plastics Inc. 300 International Drive, Suite 100 Williamsville, NY 14221 800-682-2525 http://www.armor-tile.com/
Detectable Warning Tile Composite Wet-Set	ADA Solutions, Inc. 323 Andover Street Wilmington, MA 01887 800-372-0519 http://www.adatile.com

Other detectable panels, meeting the necessary requirements may be allowed with written approval from the City Engineer's Office. In no case will the stamping of concrete be allowed as a method of creating the domes on the tactile warning panels.

SALVAGING, STOCKPILING, AND PLACING TOPSOIL

Existing vegetation shall be salvaged, incorporated and placed with the topsoil as far as practicable.

The areas to be covered with topsoil to a depth of +/- 3 inches comprise all newly graded areas. Material shall be free of rock and debris.

The estimated amounts of salvaged topsoil required to cover the designated areas to the specified depth are as follows:

Table of Topsoil	Cu.Yd.
3 RD AND GREEN ST	80

SEEDING

All grass areas disturbed by construction are to be hydro-mulched. Lump sum price will be for all areas disturbed by Contractor. Price shall also include the cost for fertilizer and fiber mulch, refer to SD-DOT Standard Specs 2015 Edition section 730 and 731. The following will be provided, by the Contractor, for use on the project unless an alternate is approved by the Engineer.

The estimated amount of area to be seeded: 9000 SF

SEED MIXTURE	PURE LIVE SEED/ 1000 FT. SQ.
Kentucky Bluegrass	1 pound
Perennial Rye Grass	1 pound
Park Kentucky Bluegrass	1 pound

FERTILIZER AND MULCHING

Fertilizer shall be a guaranteed analysis of 12-24-6. Rate applied shall be 3.2 lbs. per 1000 S.F. All areas shall be wood fiber mulched at a rate of 50 lbs./1000 S.F. with tackifier at a rate of 1.5lbs./1000 S.F. Method of payment will be incidental to the seeding lump sum bid price. Refer to SD-DOT Specs. 2015 Edition-section 731 and 732 for additional requirement for fertilizer and fiber mulch.

PRIVATE SPRINKLER SYSTEMS

Private sprinkler systems that are located within the construction limits. The City will notify all property owners about the expected construction and the procedures for preparing their systems for construction. When found, the Contractor shall notify the Engineer and take reasonable measures to minimize any damage to the system. It will be the responsibility of the City to pay the property owner's sprinkler contractor directly for repairs. The Contractor will be responsible for any damaged due to Contractor's negligence.

The Contractor shall notify the Engineer when the sprinkler system can be restored and the City will coordinate with the property owner and sprinkler contractor. The system should be restored before seed or sod placement and the Contractor shall make reasonable accommodations to allow for the homeowner's sprinkler contractor to make final repairs and adjustments.

WATERING

Water for compaction is incidental to other pay items. Water from city fire hydrants is to be metered and paid for by Contractor.

JOB CONTROL	
CP 2	N 209648.9890 E 2754209.6810 ELEV. 1219.220
CP 3	N 209421.5370 E 2754175.5000 ELEV. 1221.32
CP 41	N 209456.7170 E 2753910.0240 ELEV. 1231.704
CP 55	N 209469.6550 E 2753860.0730 ELEV. 1234.104

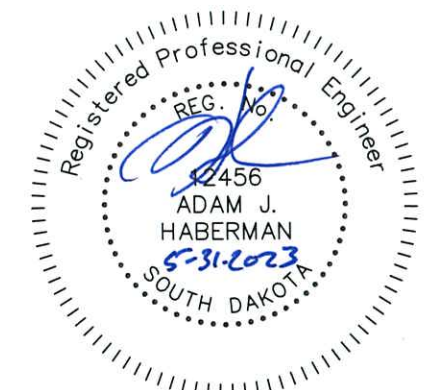

REGION NO.	STATE OF	PROJECT	SHEET NO.	TOTAL SHEETS
8	S.D.	2023-011	8	39
TYPICAL SECTION				

TYPICAL CROSS SECTIONS(n.t.s.) – 3RD ST MAPLE THRU GREEN

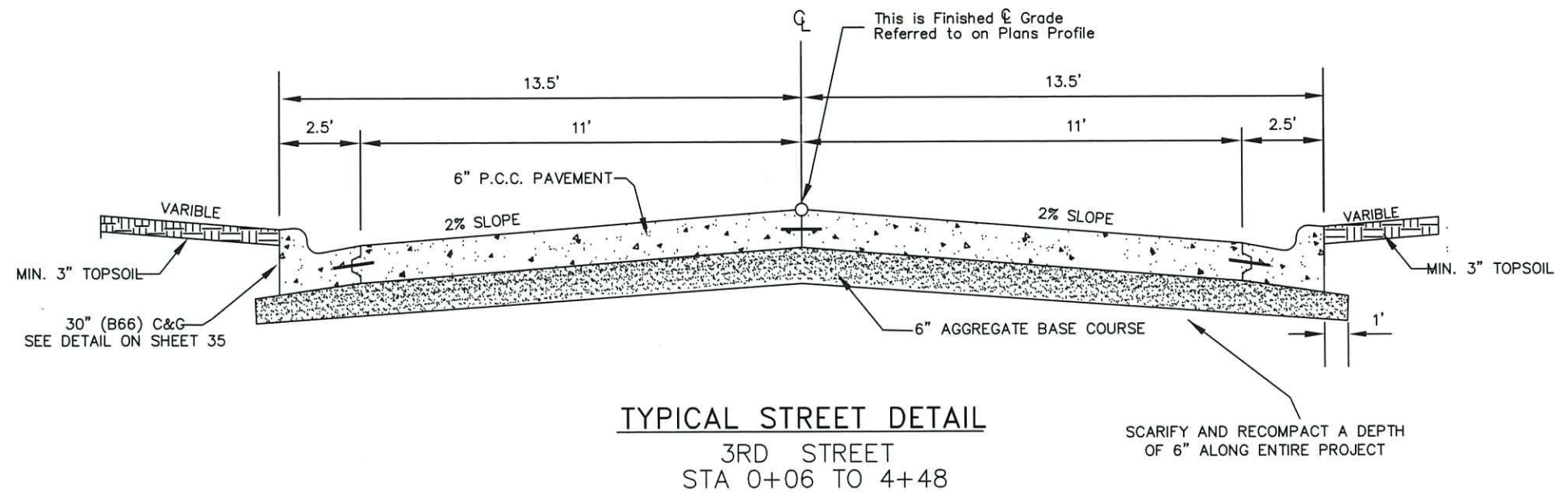

TYPICAL CROSS SECTIONS(n.t.s.) – GREEN ST 3RD TO 4TH

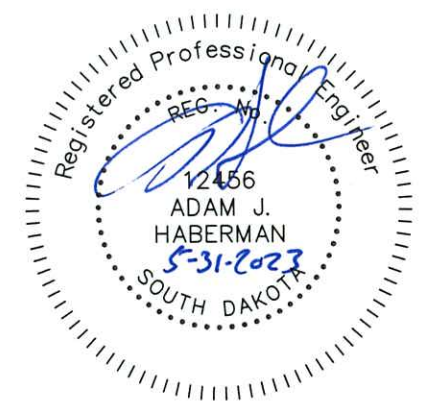
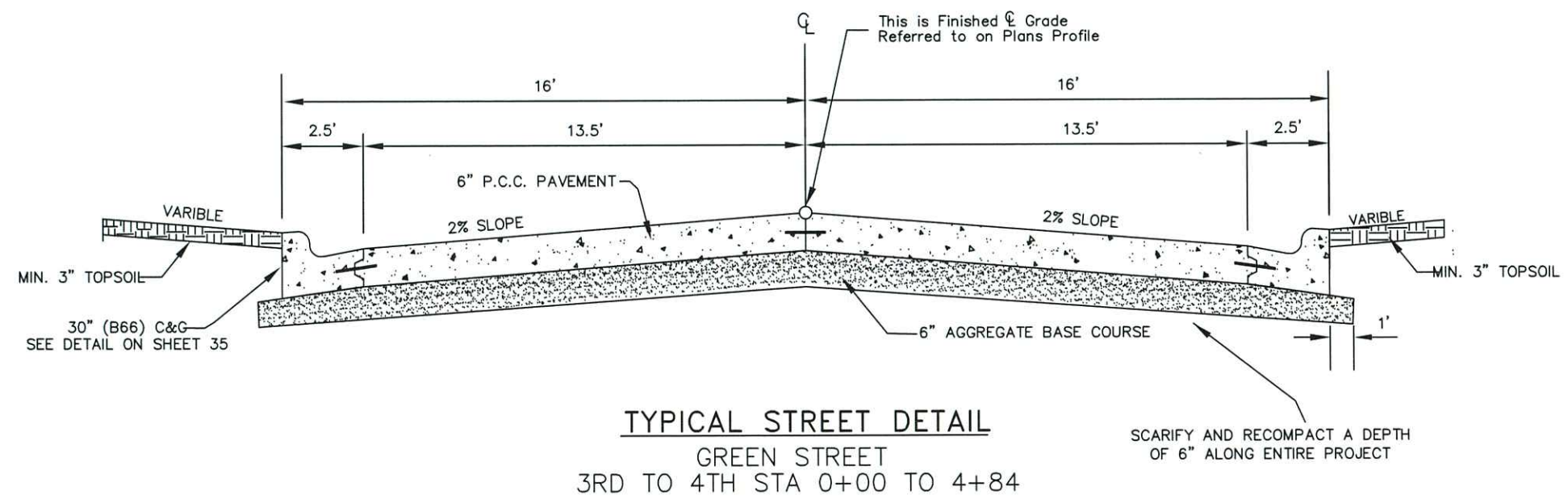

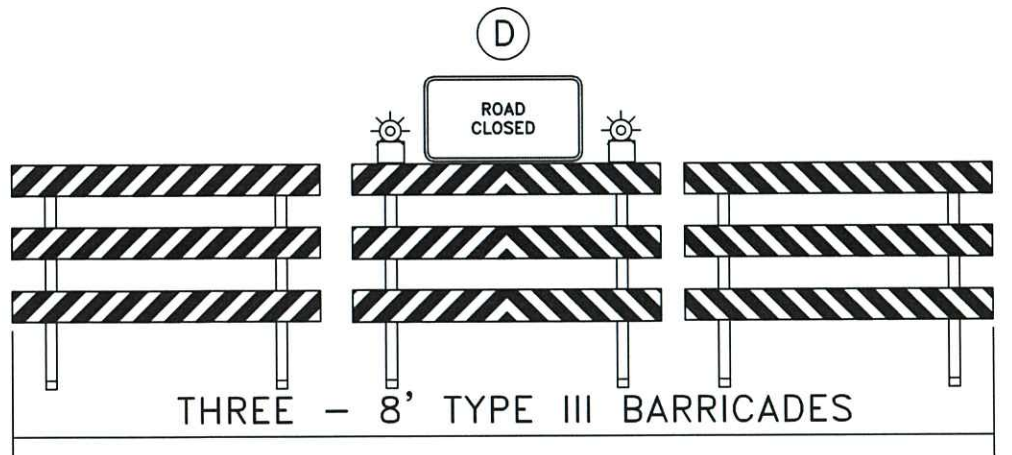
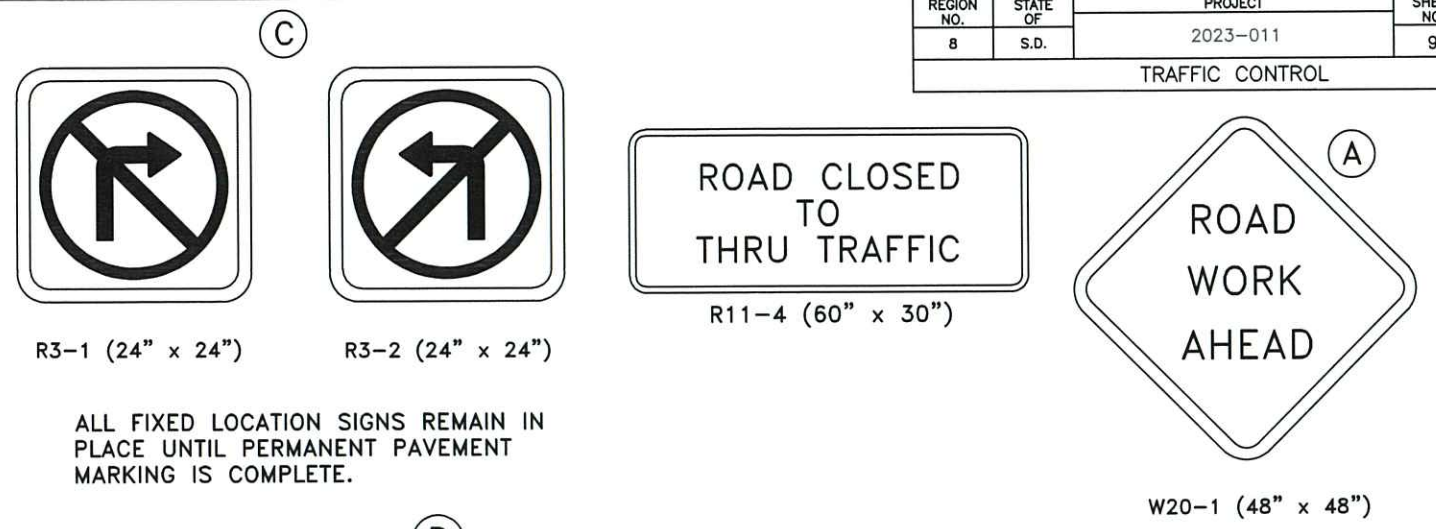

FULL ROADWAY CLOSURE

LIST OF OTHER TRAFFIC CONTROLS FOR ROAD CONSTRUCTION

BID ITEM	DESCRIPTION	QUANTITY
TRAFFIC CONTROL MISC.	TYPE I & II BARRICADES, CONES, VERTICAL PANELS, DRUMS, BARRICADE WARNING LIGHTS, DELINEATORS, WATCHMAN, TUBULAR MARKERS, AND INSTALLATION OF CITY SIGNS.	LUMP SUM

ITEMIZED LIST FOR TRAFFIC CONTROL BID ITEM

SIGN NUMBER	SIGN SIZE	DESCRIPTION	AMOUNT REQUIRED	UNITS PER AMOUNT	SUB TOTAL
R11-2	48" x 30"	ROAD CLOSED	4	27	108
R3-1	24" x 24"	NO RIGHT TURN (SYMBOL)	2	15	30
R3-2	24" x 24"	NO LEFT TURN (SYMBOL)	2	15	30
R11-4	60" x 30"	ROAD CLOSED TO THRU TRAFFIC	2	30	60
		TYPE III BARRICADES	96 L.F.	5 UNITS/L.F.	480
TOTAL					708

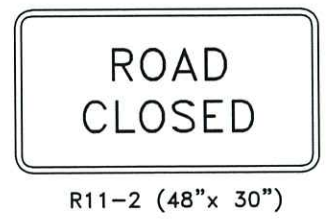

PROJECT AREA

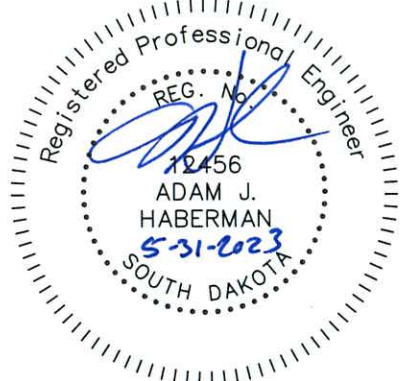

PEDESTRIAN TRAFFIC CONTROL
TRAFFIC CONTROL DEVICES FOR SIDEWALK CLOSURES AND PEDESTRIAN DETOURS SHALL BE PAID FOR UNDER TRAFFIC CONTROL MISC. (SDDOT STANDARD PLATE #634.33 MAY BE USED AS A GUIDE FOR THESE SITUATIONS)



LEGEND

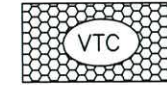

-VEHICLE TRACKING CONTROL (TYP.)
SEE DETAIL SHEET 34 PLATE # 734.02
-1 USED (WEST END OF 5TH ST.)



-SILT FENCE (TYP.)
SEE SHEET # 34
60 L.F. USED



PROJECT AREA



-INLET PROTECTION (TYP.)
SEE SHEET # 35
-2 USED AT NORTH END OF PROJECT STA 4+86
-1 USED AT NW COR OF INTERSECTION OF GREEN AND 3RD
-1 USED AT SOUTH END OF PROJECT STA 0+00

NOTE:
ALL EROSION CONTROL ITEMS SHALL BE MAINTAINED DAILY AND BE KEPT IN FULL FUNCTIONAL CONDITION TO MINIMIZE AND CONTROL SOIL RUN OFF THAT COULD OCCUR DURING THE PROJECT CONSTRUCTION. EROSION CONTROL ITEMS SHALL BE KEPT IN PLACE UNTIL PROJECT COMPLETION.

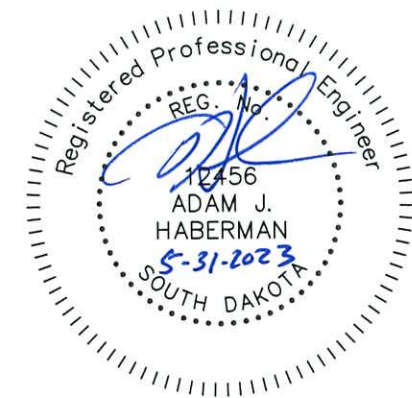

STORM WATER POLLUTION PREVENTION PLAN

(The numbers right of the title headings are **reference numbers** to the **GENERAL PERMIT FOR STORM WATER DISCHARGES ASSOCIATED WITH CONSTRUCTION ACTIVITIES**)

❖ SITE DESCRIPTION (4.2 1)

- **Project Limits:** See Title Sheet (4.2 1.b)
- **Project Description:** See Title Sheet (4.2 1.a.)
- **Site Map(s):** See Title Sheet and Plans (4.2 1.f. (1)-(6))
- **Major Soil Disturbing Activities** (check all that apply)
 - Clearing and grubbing
 - Excavation/borrow
 - Grading and shaping
 - Filling
 - Cutting and filling
 - Other (describe):
- **Total Project Area** .90 acres (4.2 1.b.)
- **Total Area To Be Disturbed** .50 acres (4.2 1.b.)
- **Existing Vegetative Cover (%)** 25%
- **Soil Properties:** AASHTO Soil Classification (4.2 1. d.)
- **Name of Receiving Water Body/Bodies** Missouri River (4.2 1.e.)

❖ ORDER OF CONSTRUCTION ACTIVITIES (4.2 1.c.)

(Stabilization measures shall be initiated as soon as possible, but in no case later than 14 days after the construction activity in that portion of the site has temporarily or permanently ceased. Initiation of final or temporary stabilization may exceed the 14-day limit if earth disturbing activities will be resumed within 21 days.)

- **Special sequencing requirements** (see sheet).
- **Install stabilized construction entrance(s).**
- **Install perimeter protection where runoff sheets from the site.**
- **Install channel and ditch bottom protection.**
- **Clearing and grubbing.**
- **Remove and store topsoil.**
- **Stabilize disturbed areas.**
- **Install utilities, storm sewers, curb and gutter.**
- **Install inlet and culvert protection after completing storm drainage and other utility installations.**
- **Complete final grading.**
- **Complete final paving and sealing of concrete.**
- **Complete traffic control installation and protection devices.**
- **Reseed areas disturbed by removal activities.**

❖ EROSION AND SEDIMENT CONTROLS (4.2 2.a.(1)(a)-(f))

(Check all that apply)

- **Stabilization Practices (See Detail Plan Sheets)**
 - Temporary or Permanent Seeding
 - Sodding
 - Planting
 - Mulching (Straw or Cellulose Fiber)
 - Erosion Control Blankets or Mats
 - Vegetation Buffer Strips
 - Roughened Surface (e.g. tracking)
 - Gabions-Gabion Mattress
 - Other

➤ Structural Temporary Erosion and Sediment Controls

- Silt Fence
- Straw Bale Check
- Temporary Berm
- Temporary Slope Drain
- Straw Wattles or Rolls
- Diversion Channels/Swales
- Channel Liners (TRM)
- Stone Rip Rap Sheet
- Rock Check Dams
- Sediment Traps/Basins
- Inlet Protection
- Outlet Protection
- Surface Inlet Protection
- Curb Inlet Protection
- Stabilized Construction Entrances
- Other

➤ Wetland Avoidance

Will construction and/or erosion and sediment controls impinge on regulated wetlands? Yes No If yes, the structural and erosion and sediment controls have been included in the total project wetland impacts and have been included in the 404 permit process with the USACE.

➤ Storm Water Management (4.2 2.b., (1) and (2))

Storm water management will be handled by temporary controls outlined in Section 3 above, and any permanent controls needed to meet permanent storm water management needs in the post construction period. Permanent controls will be shown on the plans and noted as permanent.

➤ Other Storm Water Controls (4.2 2.c., (1) and (2))

- **Waste Disposal**
All liquid waste materials will be collected and stored in sealed metal containers approved by the project engineer. All trash and construction debris from the site will be deposited in the approved containers. Containers will be serviced as necessary, and the trash will be hauled to an approved disposal site or licensed landfill. All onsite personnel will be instructed in the proper procedures for waste disposal, and notices stating proper practices will be posted in the field office. The general contractor's representative responsible for the conduct of work on the site will be responsible for seeing waste disposal procedures are followed.
- **Hazardous Waste**
All hazardous waste materials will be disposed of in a manner specified by local or state regulations or by the manufacturer. Site personnel will be instructed in these practices, and the individual designated as the contractor's on-site representative will be responsible for seeing that these practices are followed.
- **Sanitary Waste**
Portable sanitary facilities will be provided on all construction sites. Sanitary waste will be collected from the portable units in a timely manner by a licensed waste management contractor or as required by any local regulations.

❖ Maintenance and Inspection (4.2 3. and 4.2 4.)

- **Maintenance and Inspection Practices**
 - Inspections will be conducted at least one time per week and after a storm event of 0.50 inches or greater.
 - All controls will be maintained in good working order. Necessary repairs will be initiated within 24 hours of the site inspection report.

➤ Maintenance and Inspection Practices(Continued)

- Silt fence will be inspected for depth of sediment and for tears in order to ensure the fabric is securely attached to the posts and that the posts are well anchored. Sediment buildup will be removed from the silt fence when it reaches $\frac{1}{3}$ of the height of the silt fence.
- Sediment basins and traps will be checked. Sediment will be removed when depth reaches approximately 50 percent of the structure's capacity, and at the conclusion of the construction.
- Check dams will be inspected for stability. Sediment will be removed when depth reaches $\frac{1}{2}$ the height of the dam.
- All seeded areas will be checked for bare spots, washouts, and vigorous growth free of significant weed infestations.
- Inspection and maintenance reports will be prepared on form DOT 298 for each site inspection, this form will also be used to document changes to the SWPPP. A copy of the completed inspection form will be filed with the SWPPP documents.
- The City Engineer and contractor's site superintendent are responsible for inspections. Maintenance, repair activities are the responsibility of the contractor. The City Engineer will complete the inspection and maintenance reports and distribute copies per the distribution instructions on DOT 298.

❖ Non-Storm Water Discharges (3.0)

The following non-storm water discharges are anticipated during the course of this project (check all that apply).

- Discharges from water line flushing.
- Pavement wash-water, where no spills or leaks of toxic or hazardous materials have occurred.
- Uncontaminated ground water associated with dewatering activities.

❖ Materials Inventory (4.2. 2.c.(2))

The following materials or substances are expected to be present on the site during the construction period. These materials will be handled as noted under the headings "EROSION AND SEDIMENT CONTROLS" and "SPILL PREVENTION" (check all that apply).

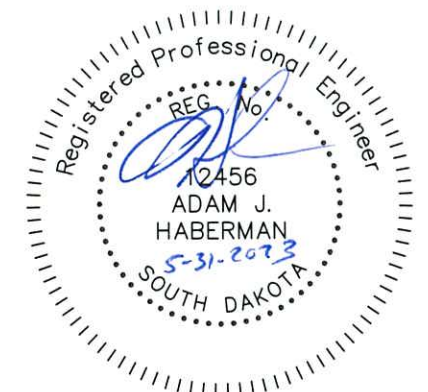

❖ **Spill Prevention (4.2 2.c.(2))**

➤ **Material Management**

▪ **Housekeeping**

- Only needed products will be stored on-site by the contractor.
- Except for bulk materials the contractor will store all materials under cover and in appropriate containers.
- Products must be stored in original containers and labeled.
- Material mixing will be conducted in accordance with the manufacturer's recommendations.
- When possible, all products will be completely used before properly disposing of the container off site.
- The manufacturer's directions for disposal of materials and containers will be followed.
- The contractor's site superintendent will inspect materials storage areas regularly to ensure proper use and disposal.
- Dust generated will be controlled in an environmentally safe manner.
- Vegetation areas not essential to the construction project will be preserved and maintained as noted on the plans.

▪ **Hazardous Materials**

- Products will be kept in original containers unless the container is not resealable.
- Original labels and material safety data sheets will be retained in a safe place to relay important product information.
- If surplus product must be disposed of, manufacturer's label directions for disposal will be followed.
- Maintenance and repair of all equipment and vehicles involving oil changes, hydraulic system drain down, de-greasing operations, fuel tank drain down and removal, and other activities which may result in the accidental release of contaminants will be conducted on an impervious surface and under cover during wet weather to prevent the release of contaminants onto the ground.
- Wheel wash water will be collected and allowed to settle out suspended solids prior to discharge. Wheel wash water will not be discharged directly into any storm water system or storm water treatment system.
- Potential pH-modifying materials such as: bulk cement, cement kiln dust, fly ash, new concrete washings, concrete pumping, and mixer washout waters will be collected on site and managed to prevent contamination of storm water runoff.

➤ **Product Specific Practices (6.8)**

▪ **Petroleum Products**

All on-site vehicles will be monitored for leaks and receive regular preventive maintenance to reduce the chance of leakage. Petroleum products will be stored in tightly sealed containers which are clearly labeled.

▪ **Fertilizers**

Fertilizers will be applied only in the amounts specified by the Plans. Once applied, fertilizers will be worked into the soil to limit the exposure to storm water. Fertilizers will be stored in an enclosed area. The contents of partially used fertilizer bags will be transferred to sealable containers to avoid spills.

➤ **Product Specific Practices (6.8) (Continued)**

▪ **Paints**

All containers will be tightly sealed and stored when not required for use. The excess will be disposed of according to the manufacturer's instructions and any applicable state and local regulations.

▪ **Concrete Trucks**

Contractors will provide designated truck washout areas on the site. These areas must be self contained and not connected to any storm water outlet of the site. Upon completion of construction washout areas will be properly stabilized.

➤ **Spill Control Practices (4.2 2 c.(2))**

In addition to the previous housekeeping and management practices, the following practices will be followed for spill prevention and cleanup if needed.

- For all hazardous materials stored on site, the manufacturer's recommended methods for spill clean up will be clearly posted. Site personnel will be made aware of the procedures and the locations of the information and cleanup supplies.
- Appropriate cleanup materials and equipment will be maintained by the contractor in the materials storage area on-site. As appropriate, equipment and materials may include items such as booms, dust pans, mops, rags, gloves, goggles, kitty litter, sand, sawdust, and plastic and metal trash containers specifically for clean up purposes.
- All spills will be cleaned immediately after discovery and the materials disposed of properly.
- The spill area will be kept well ventilated and personnel will wear appropriate protective clothing to prevent injury from contact with a hazardous substance.
- After a spill a report will be prepared describing the spill, what caused it, and the cleanup measures taken. The spill prevention plan will be adjusted to include measures to prevent this type of spill from reoccurring, as well as clean up instructions in the event of reoccurrences.
- The contractor's site superintendent, responsible for day-to-day operations, will be the spill prevention and cleanup coordinator. The contractor is responsible for ensuring that the site superintendent has had appropriate training for hazardous materials handling, spill management, and cleanup.

➤ **Spill Response (4.2 2 c.(2))**

The primary objective in responding to a spill is to quickly contain the material(s) and prevent or minimize migration into storm water runoff and conveyance systems. If the release has impacted on-site storm water, it is critical to contain the released materials on-site and prevent their release into receiving waters. If a spill of pollutants threatens storm water or surface water at the site, the spill response procedures outlined below must be implemented in a timely manner to prevent the release of pollutants.

- The contractor's site superintendent will be notified immediately when a spill or the threat of a spill is observed. The superintendent will assess the situation and determine the appropriate response.
- If spills represent an imminent threat of escaping erosion and sediment controls and entering receiving waters, personnel will be directed to respond immediately to contain the release and notify the superintendent after the situation has been stabilized.

➤ **Spill Response (4.2 2 c.(2)) (Continued)**

- Spill kits containing appropriate materials and equipment for spill response and cleanup will be maintained by the contractor at the site.
- If oil sheen is observed on surface water (e.g. settling ponds, detention ponds, swales), action will be taken immediately to remove the material causing the sheen. The contractor will use appropriate materials to contain and absorb the spill. The source of the oil sheen will also be identified and removed or repaired as necessary to prevent further releases.
- If a spill occurs the superintendent or the superintendent's designee will be responsible for completing the spill reporting form and for reporting the spill to SD DENR.
- Personnel with primary responsibility for spill response and clean up will receive training by the contractor's site superintendent or designee. The training must include identifying the location of the spill kits and other spill response equipment and the use of spill response materials.
- Spill response equipment will be inspected and maintained as necessary to replace any materials used in spill response activities.

❖ **Spill Notification**

In the event of a spill, the contractor's site superintendent will make the appropriate notification(s), consistent with the following procedures:

- A reportable spill is a quantity of 25 gallons or more or any spill of oil which: 1) violates water quality standards, 2) produces a "sheen" on a surface water, or 3) causes a sludge or emulsion must be reported immediately to the National Response Center.
- Any spill of oil or hazardous substance to waters of the state must be reported immediately by telephone to the SD DENR.

❖ **Construction Changes (4.4)**

When changes are made to the construction project that will require alterations in the temporary erosion controls of the site, the Storm Water Pollution Prevention Plan (SWPPP) will be amended to provide appropriate protection to disturbed areas, all storm water structures, and adjacent waters. The City Engineer will modify the SWPPP plan (DOT 298) and drawings to reflect the needed changes. Copies of changes will be routed per DOT 298. Copies of forms and the SWPPP will be retained in a designated place for review over the course of the project.

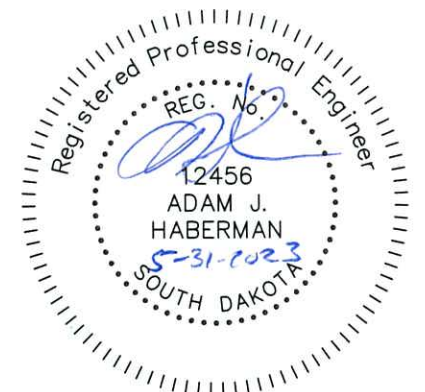

REGION NO.	STATE OF	PROJECT	SHEET NO.	TOTAL SHEETS
8	S.D.	2023-011	13	39
SWPPP				

❖ **CERTIFICATIONS**

➤ **Certification of Compliance with Federal, State, and Local Regulations**

The Storm Water Pollution Prevention Plan (SWPPP) for this project reflects the requirements of all local municipal jurisdictions for storm water management and sediment and erosion control as established by ordinance, as well as other state and federal requirements for sediment and erosion control plans, permits, notices or documentation as appropriate.

➤ **City of Yankton**

I certify under penalty of law that this document and all attachments were prepared under my direction or supervision in accordance with a system designed to assure that qualified personnel properly gather and evaluate the information submitted. Based on my inquiry of the person or persons who manage the system, or those persons directly responsible for gathering the information, the information submitted is, to the best of my knowledge and belief, true, accurate, and complete. I am aware that there are significant penalties for submitting false information, including the possibility of fine and imprisonment for knowing violations.

Authorized Signature. (See the General Permit, Section 6.7.1.C.)

➤ **Prime Contractor**

This section is to be executed by the General Contractor after the award of the contract and at least 15 days prior to the beginning of construction. This section may be executed any time there is a change in the Prime Contractor of the project.

I certify under penalty of law that this document and all attachments were prepared under my direction or supervision in accordance with a system designed to assure that qualified personnel properly gather and evaluate the information submitted. Based on my inquiry of the person or persons who manage the system, or those persons directly responsible for gathering the information, the information submitted is, to the best of my knowledge and belief, true, accurate, and complete. I am aware that there are significant penalties for submitting false information, including the possibility of fine and imprisonment for knowing violations.

Authorized Signature. (See the General Permit, Section 6.7.1.a .or b.)

❖ **CONTACT INFORMATION**

➤ **Contractor Information:**

- Prime Contractor Name:
- Contractor Contact Name:
- Address:
- Address:
- City: State: Zip:
- Office Phone: Field: Cell: Fax:

Erosion Control Supervisor

- Name:
- Address:
- Address:
- City: State: Zip:
- Office Phone: Cell: Fax:

➤ **City Engineer**

- Name: Brad Moser
- Business Address: 416 Walnut
- Job Office Location 416 Walnut
- City: Yankton State: SD Zip: 57078
- Office Phone: 605-668-5255 Field: Cell: Fax:

➤ **SD DENR Contact Spill Reporting**

- Business Hours Monday-Friday (605) 773-3296
- Nights and Weekends (605) 773-3231

➤ **SD DENR Contact for Hazardous Materials.**

- (605) 773-3153

➤ **National Response Center Hotline**

- (800) 424-8802.

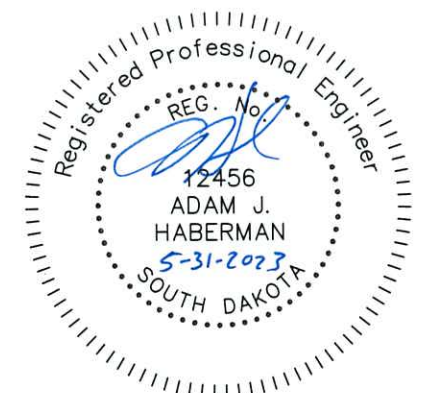





MAPLE ST.

GREEN ST.

3RD ST.

LEGEND

 REMOVE CONCRETE PAVEMENT

 REMOVE ASPHALT PAVEMENT

3RD ST HAS 2" ASPHALT ON TOP OF 4 1/2" CONCRETE
 GREEN ST HAS 1 1/2" ASPHALT ON TOP OF 4" CONCRETE

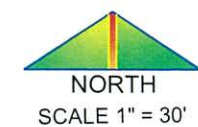
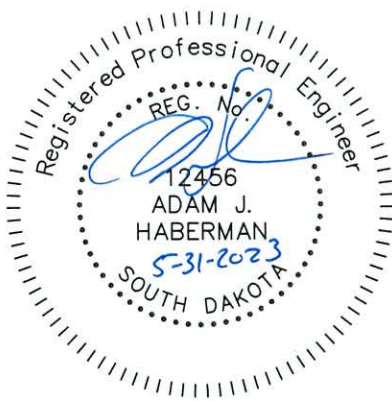

REGION NO.	STATE OF	PROJECT	SHEET NO.	TOTAL SHEETS
8	S.D.	2023-011	14	39
REMOVALS				

REGION NO.	STATE OF	PROJECT	SHEET NO.	TOTAL SHEETS
8	S.D.	2023-011	15	39
REMOVALS				

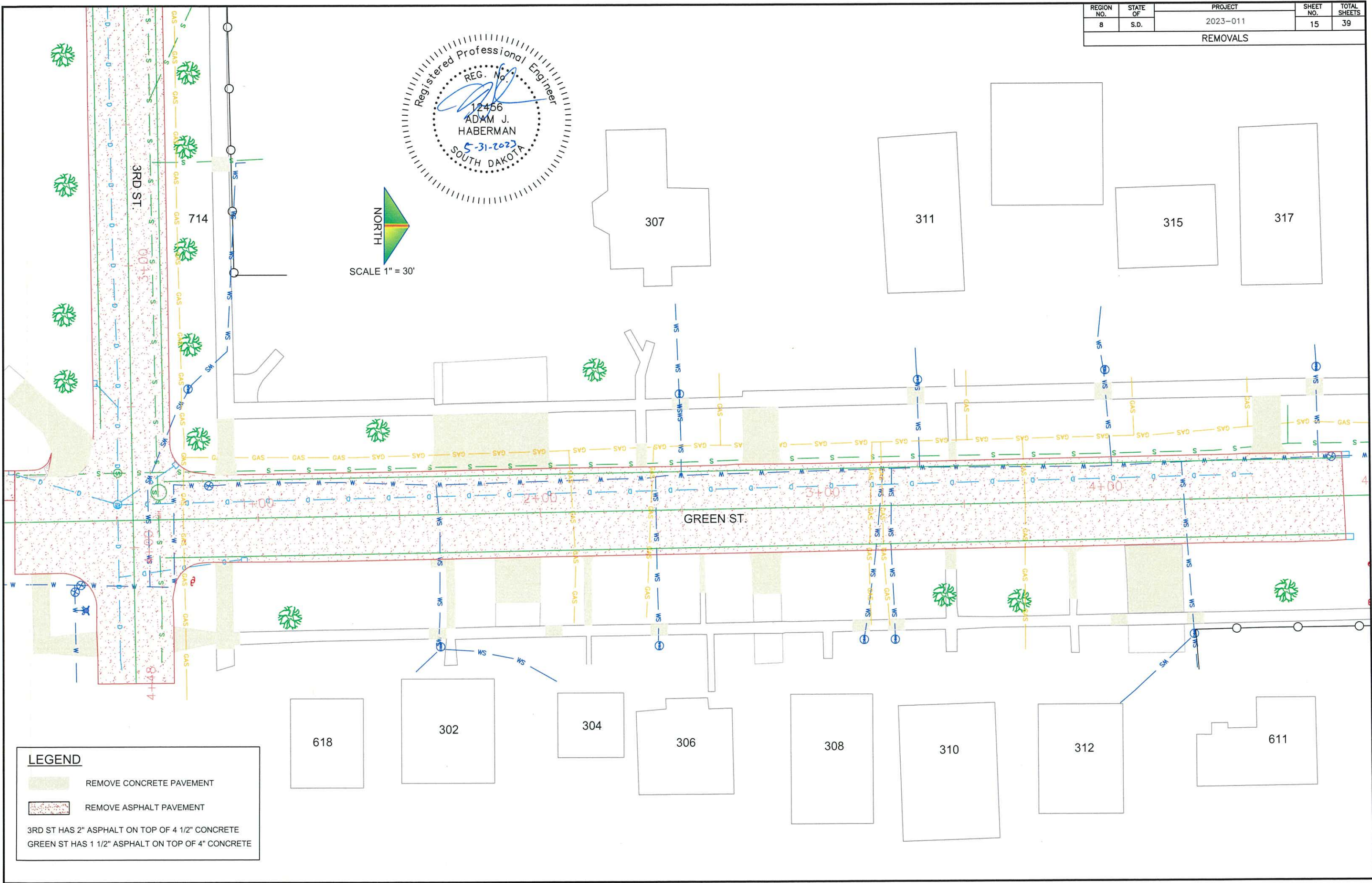
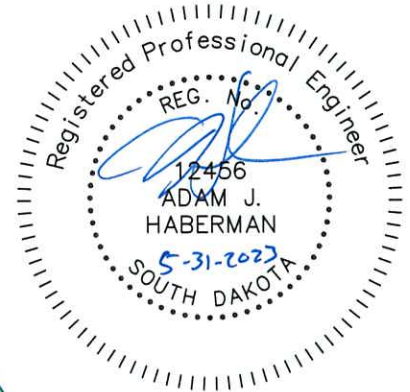

LEGEND

- REMOVE CONCRETE PAVEMENT
- REMOVE ASPHALT PAVEMENT

3RD ST HAS 2" ASPHALT ON TOP OF 4 1/2" CONCRETE
 GREEN ST HAS 1 1/2" ASPHALT ON TOP OF 4" CONCRETE

MAPLE ST.

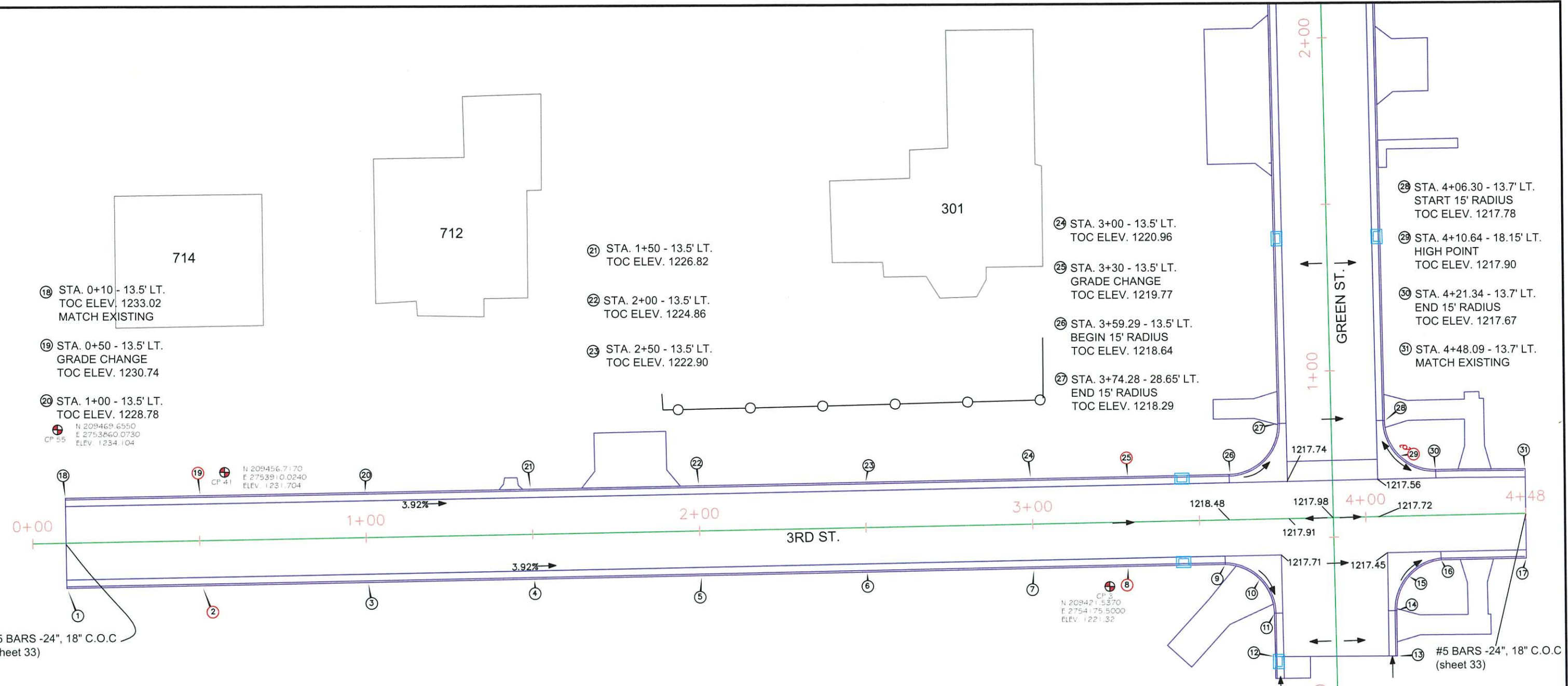

- 18 STA. 0+10 - 13.5' LT.
TOC ELEV. 1233.02
MATCH EXISTING
- 19 STA. 0+50 - 13.5' LT.
GRADE CHANGE
TOC ELEV. 1230.74
- 20 STA. 1+00 - 13.5' LT.
TOC ELEV. 1228.78

CP 55
N 209469.6550
E 2753860.0730
ELEV. 1234.104

CP 41
N 209456.7170
E 2753910.0240
ELEV. 1231.704

- 24 STA. 3+00 - 13.5' LT.
TOC ELEV. 1220.96
- 25 STA. 3+30 - 13.5' LT.
GRADE CHANGE
TOC ELEV. 1219.77
- 26 STA. 3+59.29 - 13.5' LT.
BEGIN 15' RADIUS
TOC ELEV. 1218.64
- 27 STA. 3+74.28 - 28.65' LT.
END 15' RADIUS
TOC ELEV. 1218.29

CP 3
N 209421.5370
E 2754175.5000
ELEV. 1221.32

- 28 STA. 4+06.30 - 13.7' LT.
START 15' RADIUS
TOC ELEV. 1217.78
- 29 STA. 4+10.64 - 18.15' LT.
HIGH POINT
TOC ELEV. 1217.90
- 30 STA. 4+21.34 - 13.7' LT.
END 15' RADIUS
TOC ELEV. 1217.67
- 31 STA. 4+48.09 - 13.7' LT.
MATCH EXISTING

#5 BARS -24", 18" C.O.C
(sheet 33)

#5 BARS -24", 18" C.O.C
(sheet 33)

- 1 STA. 0+10 - 13.5' RT.
TOC ELEV. 1232.63
MATCH EXISTING
- 2 STA. 0+50 - 13.5' RT.
GRADE CHANGE
TOC ELEV. 1230.74
- 3 STA. 1+00 - 13.5' RT.
TOC ELEV. 1228.78

- 4 STA. 1+50 - 13.5' RT.
TOC ELEV. 1226.82
- 5 STA. 2+00 - 13.5' RT.
TOC ELEV. 1224.86
- 6 STA. 2+50 - 13.5' RT.
TOC ELEV. 1222.90

- 7 STA. 3+00 - 13.5' RT.
TOC ELEV. 1220.96
- 8 STA. 3+30 - 13.5' RT.
GRADE CHANGE
TOC ELEV. 1219.80
- 9 STA. 3+57.48 - 13.5' RT.
BEGIN 15' RADIUS
TOC ELEV. 1218.60
- 10 STA. 3+67.71 - 17.97' RT.
MID POINT
TOC ELEV. 1218.18

- 11 STA. 3+71.9 - 28.36' RT.
END 15' RADIUS
TOC ELEV. 1217.98
- 12 STA. 3+71.9 - 41.42' RT.
MATCH EXISTING
- 13 STA. 4+08.45 - 42.03' RT.
MATCH EXISTING
- 14 STA. 4+08.45 - 28.37' RT.
BEGIN 15' RADIUS
TOC ELEV. 1217.71

- 15 STA. 4+12.55 - 18.21' RT.
MID POINT
TOC ELEV. 1217.61
- 16 STA. 4+22.37 - 13.5' RT.
END 15' RADIUS
TOC ELEV. 1217.51
- 17 STA. 4+48.0 - 13.4' RT.
MATCH EXISTING

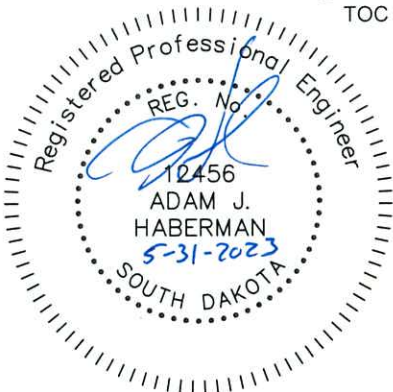

REGION NO.	STATE OF	PROJECT	SHEET NO.	TOTAL SHEETS
8	S.D.	2023-011	16	39
PAVING				

3RD RT. PROFILE

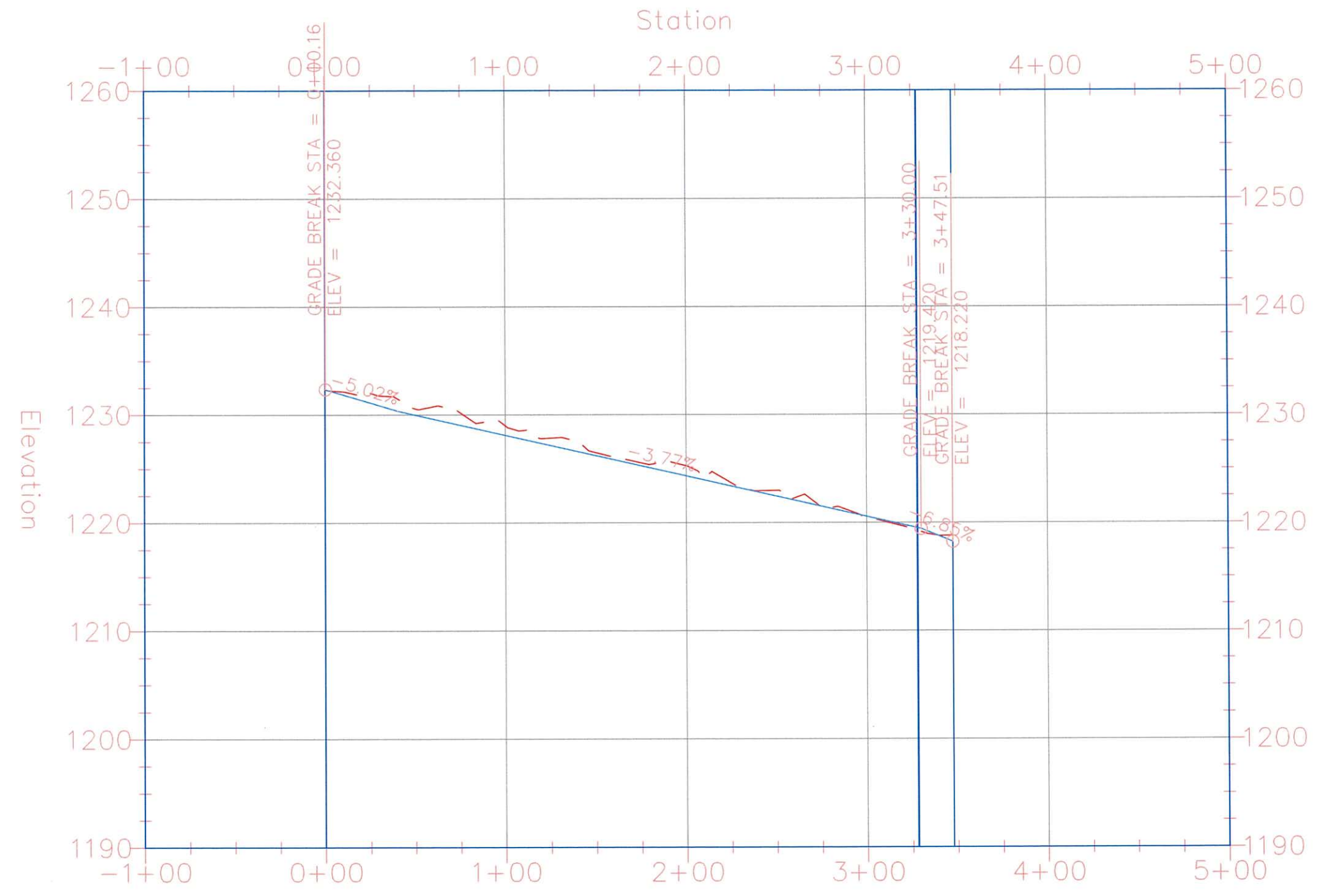

	1232.36	1228.99	1225.25	1220.50	
	1232.357	1228.987	1225.255	1220.497	
0+00	1+00	2+00	3+00	4+00	

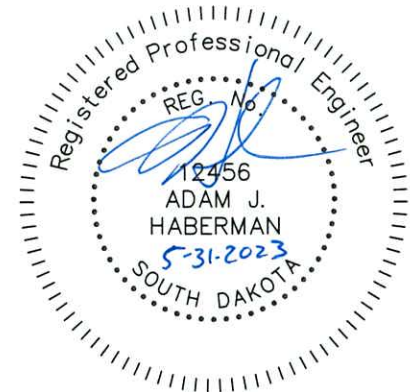

REGION NO.	STATE OF	PROJECT	SHEET NO.	TOTAL SHEETS
8	S.D.	2023-011	18	39
PAVING				

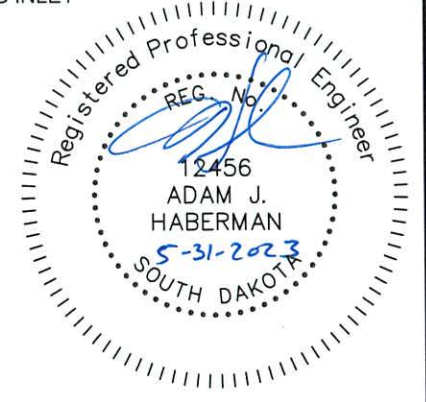
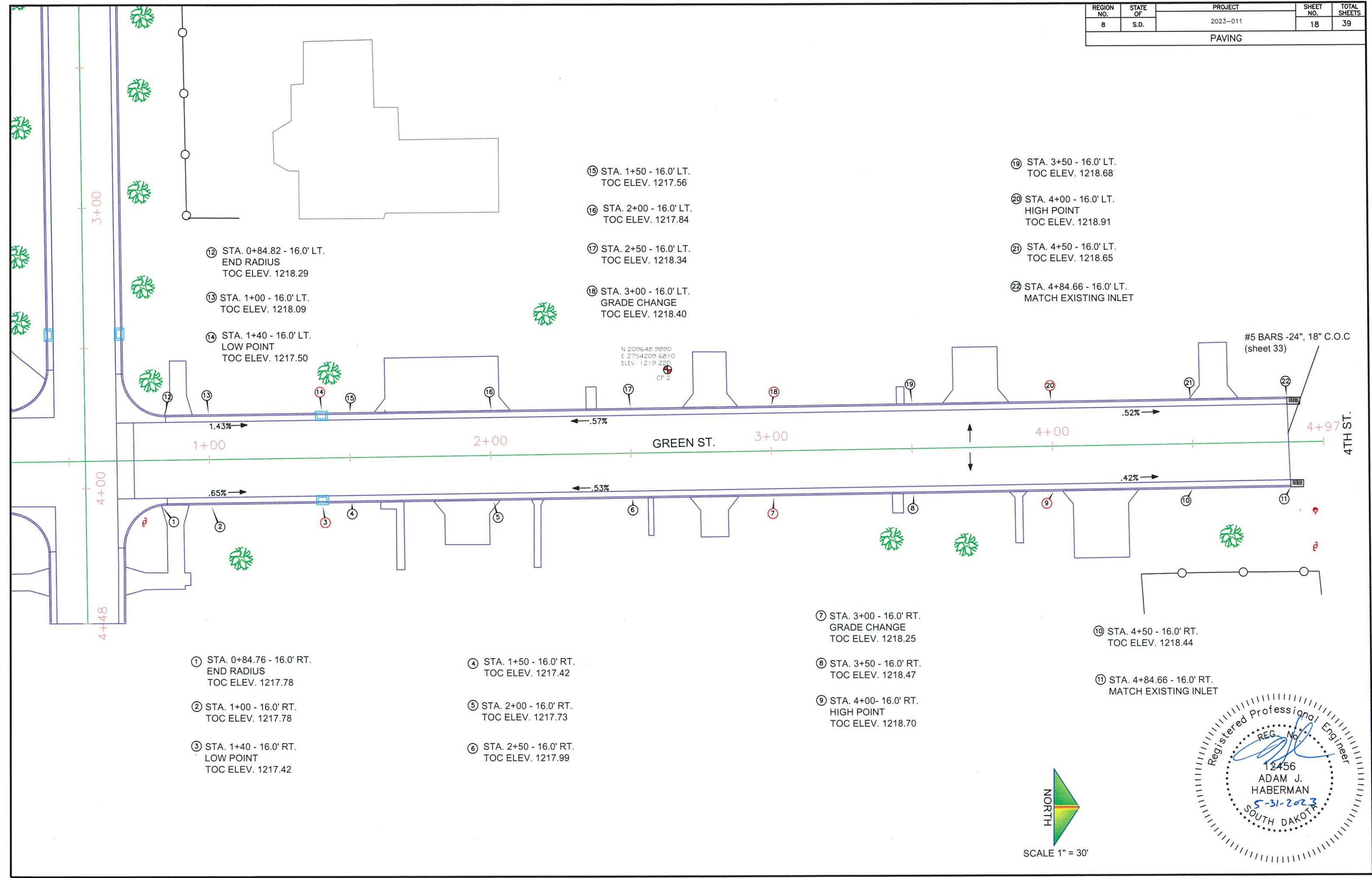

REGION NO.	STATE	PROJECT	SHEET NO.	TOTAL SHEETS
8	S.D.	2023-011	19	39

PROFILE

GREEN PROFILE

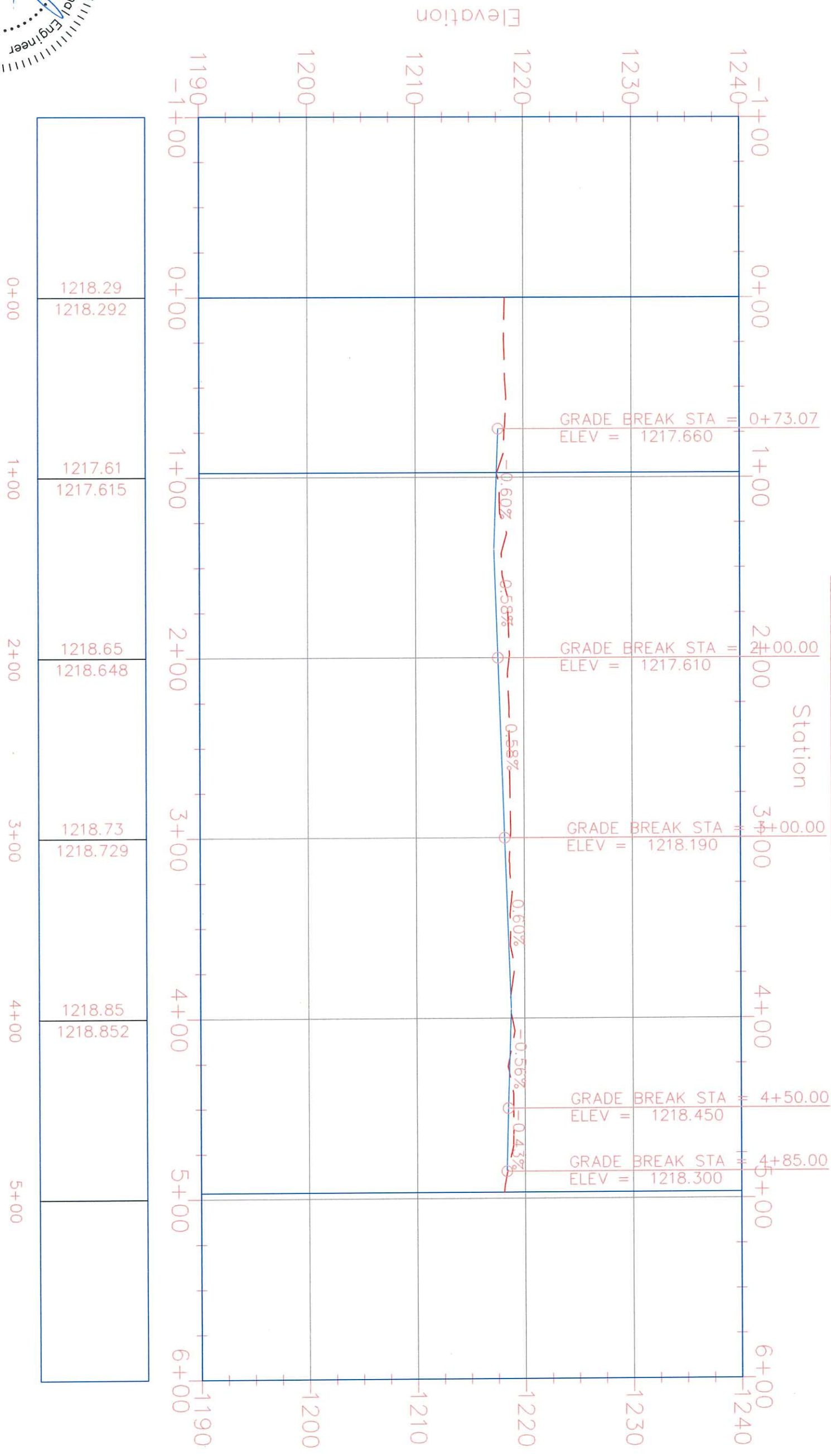

0+00	1218.29	1218.292
1+00	1217.61	1217.615
2+00	1218.65	1218.648
3+00	1218.73	1218.729
4+00	1218.85	1218.852
5+00		

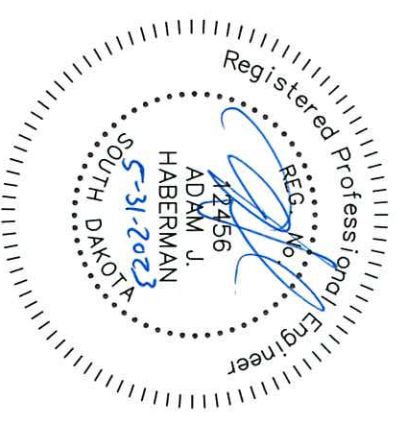

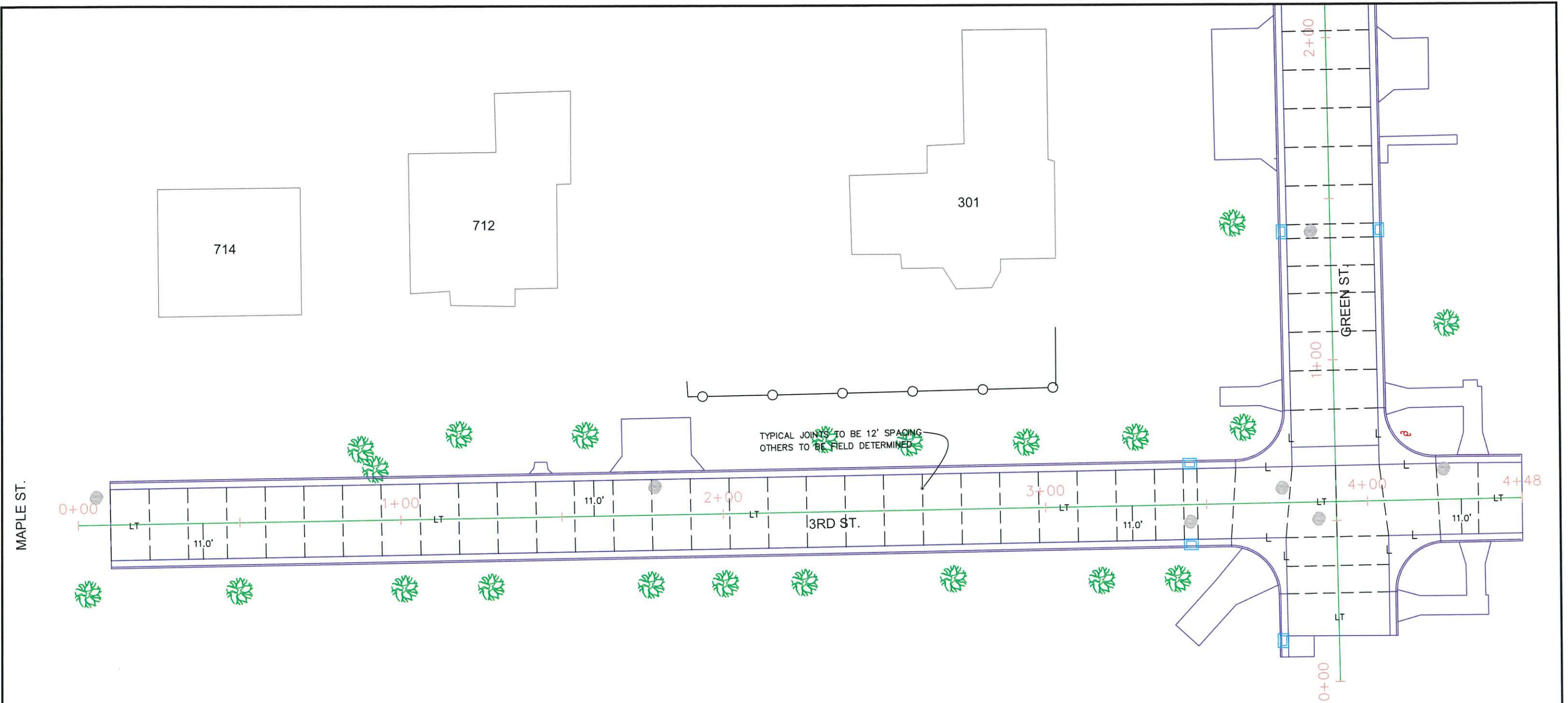

MAPLE ST.

LEGEND

- LONGITUDINAL CONSTRUCTION JOINT WITHOUT TIE BARS — L —
- LONGITUDINAL CONSTRUCTION JOINT WITH TIE BARS — LT —
- TRANSVERSE CONTRACTION JOINT - - - - -
- MANHOLES ●

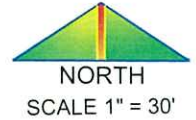

REGION NO.	STATE OF	PROJECT	SHEET NO.	TOTAL SHEETS
8	S.D.	2023-011	20	39
JOINTS				

REGION NO.	STATE OF	PROJECT	SHEET NO.	TOTAL SHEETS
8	S.D.	2023-011	21	39
JOINTS				

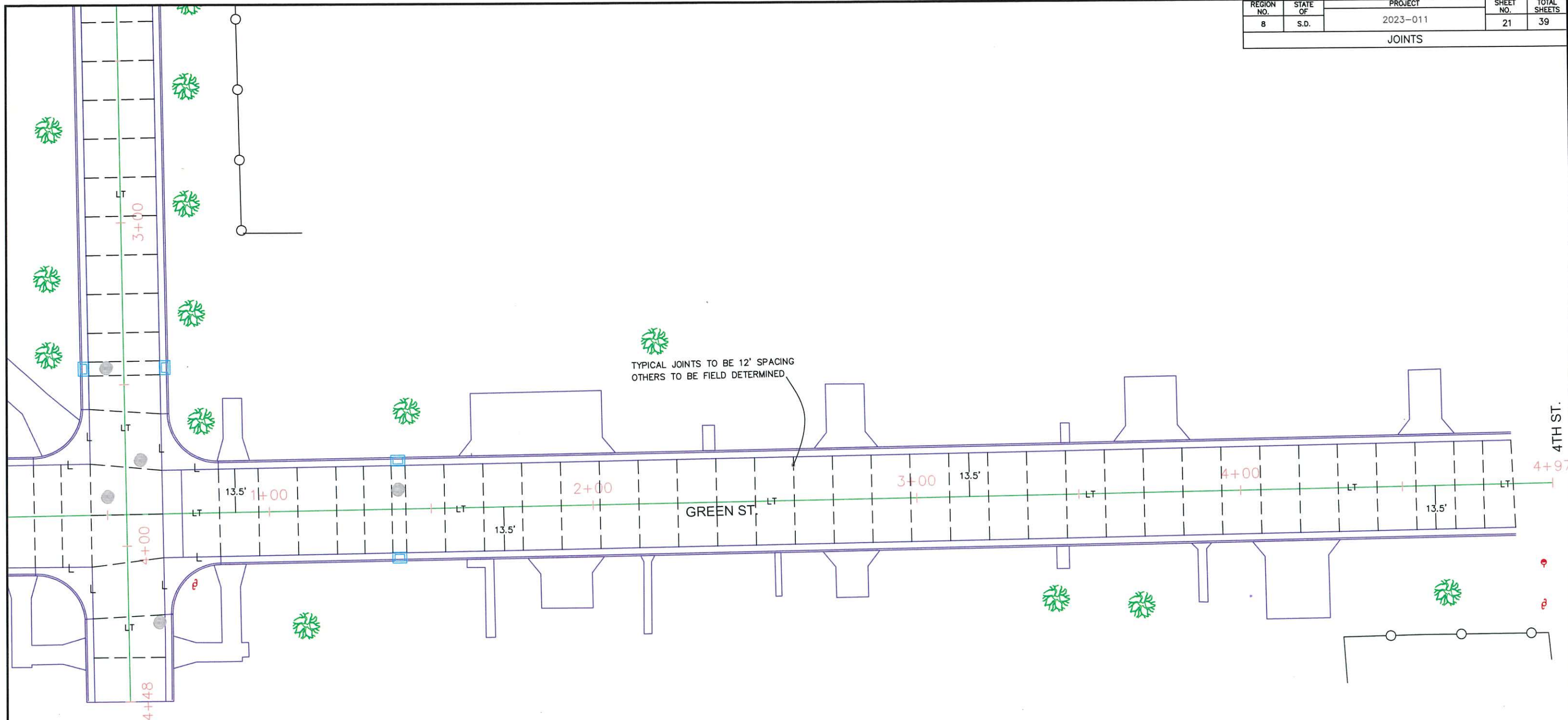

TYPICAL JOINTS TO BE 12' SPACING
OTHERS TO BE FIELD DETERMINED

LEGEND

- LONGITUDINAL CONSTRUCTION JOINT WITHOUT TIE BARS — L —
- LONGITUDINAL CONSTRUCTION JOINT WITH TIE BARS — LT —
- TRANSVERSE CONTRACTION JOINT - - - - -
- MANHOLES ●

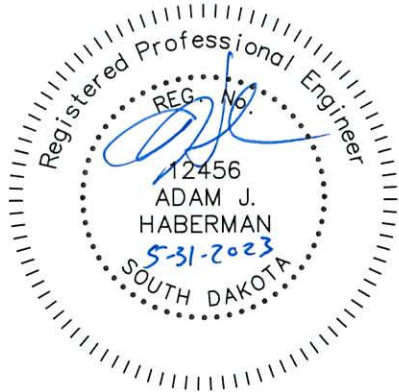

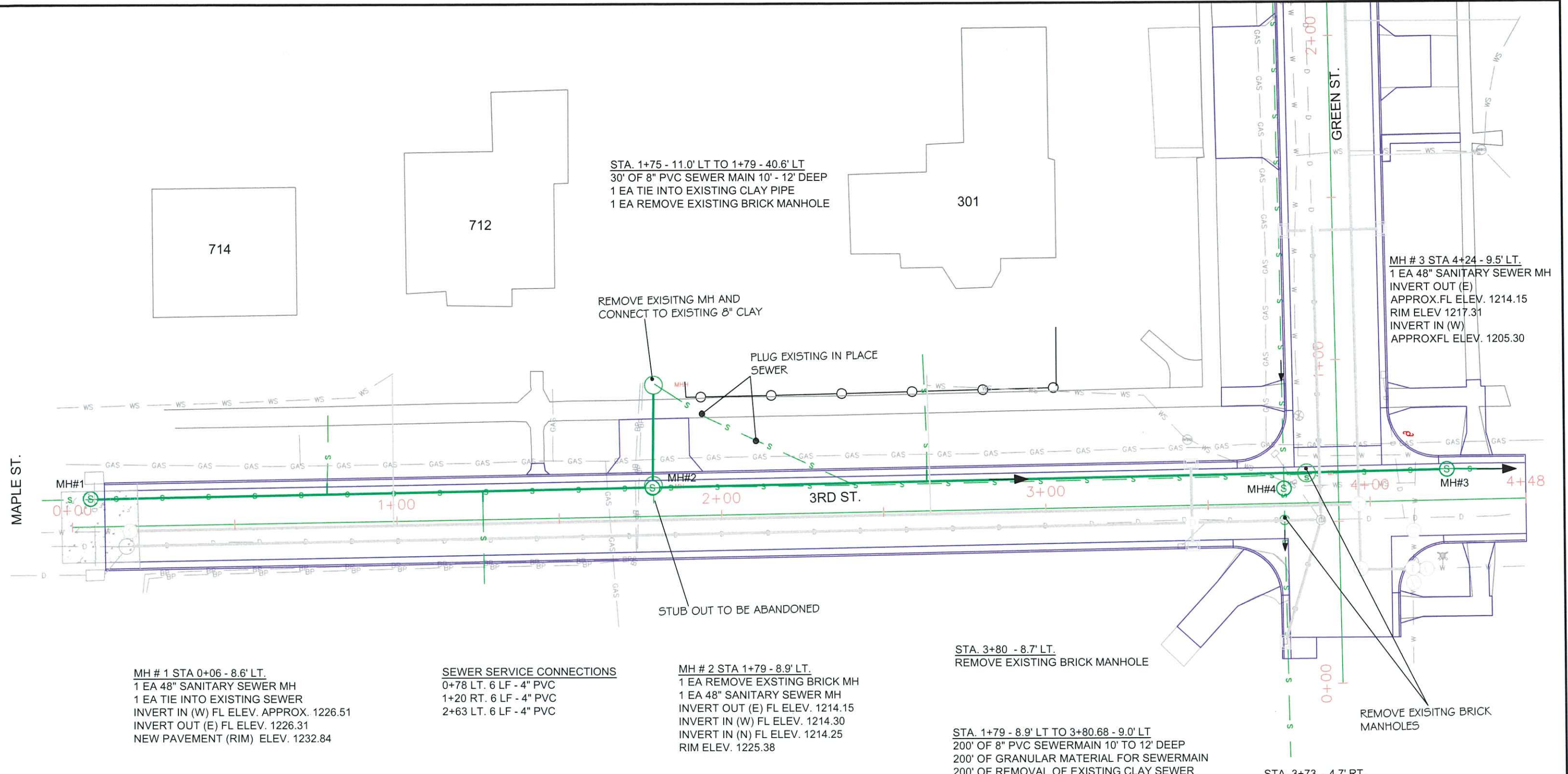

STA. 1+75 - 11.0' LT TO 1+79 - 40.6' LT
 30' OF 8" PVC SEWER MAIN 10' - 12' DEEP
 1 EA TIE INTO EXISTING CLAY PIPE
 1 EA REMOVE EXISTING BRICK MANHOLE

MH # 3 STA 4+24 - 9.5' LT.
 1 EA 48" SANITARY SEWER MH
 INVERT OUT (E)
 APPROX.FL ELEV. 1214.15
 RIM ELEV 1217.31
 INVERT IN (W)
 APPROXFL ELEV. 1205.30

MH # 1 STA 0+06 - 8.6' LT.
 1 EA 48" SANITARY SEWER MH
 1 EA TIE INTO EXISTING SEWER
 INVERT IN (W) FL ELEV. APPROX. 1226.51
 INVERT OUT (E) FL ELEV. 1226.31
 NEW PAVEMENT (RIM) ELEV. 1232.84

SEWER SERVICE CONNECTIONS
 0+78 LT. 6 LF - 4" PVC
 1+20 RT. 6 LF - 4" PVC
 2+63 LT. 6 LF - 4" PVC

MH # 2 STA 1+79 - 8.9' LT.
 1 EA REMOVE EXSTING BRICK MH
 1 EA 48" SANITARY SEWER MH
 INVERT OUT (E) FL ELEV. 1214.15
 INVERT IN (W) FL ELEV. 1214.30
 INVERT IN (N) FL ELEV. 1214.25
 RIM ELEV. 1225.38

STA. 3+80 - 8.7' LT.
 REMOVE EXISTING BRICK MANHOLE

STA. 1+79 - 8.9' LT TO 3+80.68 - 9.0' LT
 200' OF 8" PVC SEWERMAIN 10' TO 12' DEEP
 200' OF GRANULAR MATERIAL FOR SEWERMAIN
 200' OF REMOVAL OF EXISTING CLAY SEWER

STA. 3+80.68 - 9.0' LT TO 4+24 9.5' LT
 43' OF 8" PVC SEWERMAIN 10' TO 12' DEEP
 43' OF GRANULAR MATERIAL FOR SEWERMAIN
 43' OF REMOVAL OF EXISTING CLAY SEWER

STA. 3+73 - 4.7' RT.
 REMOVE EXISTING BRICK MANHOLE
 *EXISTING STORM SEWER CURRENTLY RUNS
 THROUGH SEWER MANHOLE

MH # 4 STA. 3+73 - 4.6' LT.
 1 EA 48" SANITARY SEWER MH
 RIM ELEV 1217.85
 MATCH EXISTING FL APPROX 1210.90

STA. 0+06 - 8.6' LT TO 1+79 - 8.9' LT
 173' OF 8" PVC SEWERMAIN 8' TO 10' DEEP
 173' OF GRANULAR MATERIAL FOR SEWERMAIN
 173' OF REMOVAL OF EXISTING CLAY SEWER

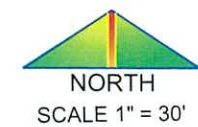
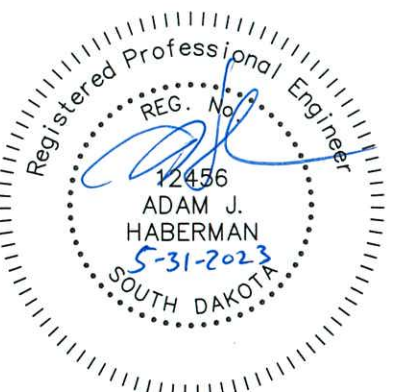

REGION NO.	STATE OF	PROJECT	SHEET NO.	TOTAL SHEETS
8	S.D.	2023-011	22	39
SEWER				

- LEGEND**
- (B) BEND
 - (S) SLEVE
 - (V) VALVE
 - (C) CAP
 - (T) TEE

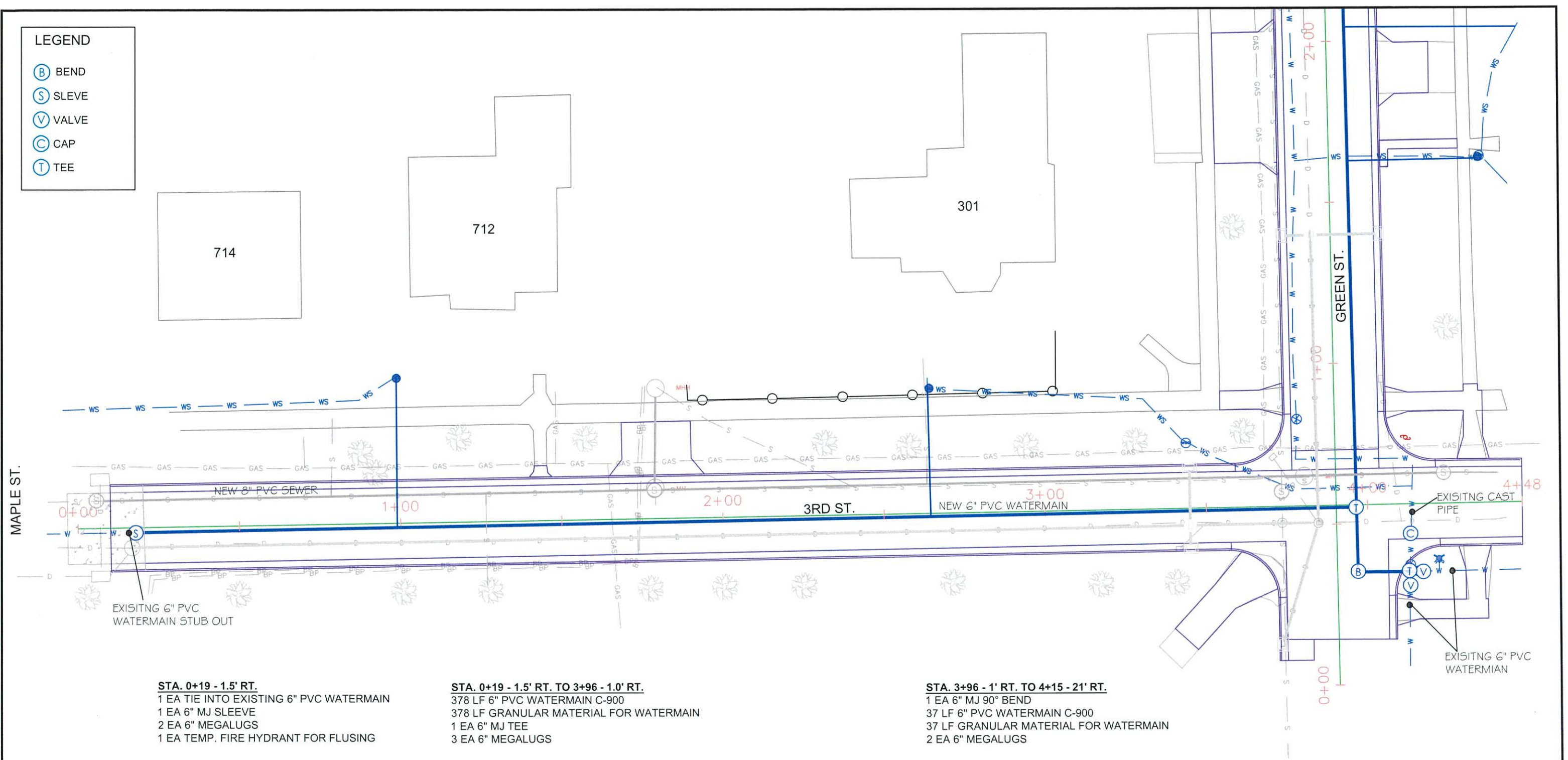

STA. 0+19 - 1.5' RT.
 1 EA TIE INTO EXISTING 6" PVC WATERMAIN
 1 EA 6" MJ SLEEVE
 2 EA 6" MEGALUGS
 1 EA TEMP. FIRE HYDRANT FOR FLUSING

STA. 0+19 - 1.5' RT. TO 3+96 - 1.0' RT.
 378 LF 6" PVC WATERMAIN C-900
 378 LF GRANULAR MATERIAL FOR WATERMAIN
 1 EA 6" MJ TEE
 3 EA 6" MEGALUGS

STA. 3+96 - 1' RT. TO 4+15 - 21' RT.
 1 EA 6" MJ 90° BEND
 37 LF 6" PVC WATERMAIN C-900
 37 LF GRANULAR MATERIAL FOR WATERMAIN
 2 EA 6" MEGALUGS

STA. 4+15 - 21' RT. TO 9' RT.
 2 EA TIE INTO EXISTING 6" PVC WATERMAIN
 1 EA 6" MJ CAP FOR OVERSIZED 6" CAST PIPE
 2 EA 6" MJ GATE VALVES
 11 EA 6" MEGALUGS
 2 EA 6" MJ SLEEVES
 2 EA REMOVE EXISTING VALVES
 1 EA 6" MJ TEE

WATER SERVICE RECONNECTIONS
 0+98 LT. 46 LF OF 1" COPPER & CURB STOP
 2+64 LT. 40 LF OF 1" COPPER & CURB STOP

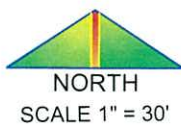
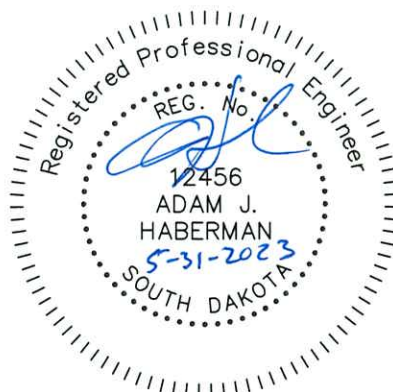

REGION NO.	STATE OF	PROJECT	SHEET NO.	TOTAL SHEETS
8	S.D.	2023-011	23	39
WATERMAIN				

REGION NO.	STATE OF	PROJECT	SHEET NO.	TOTAL SHEETS
8	S.D.	2023-011	24	39
WATERMAIN				

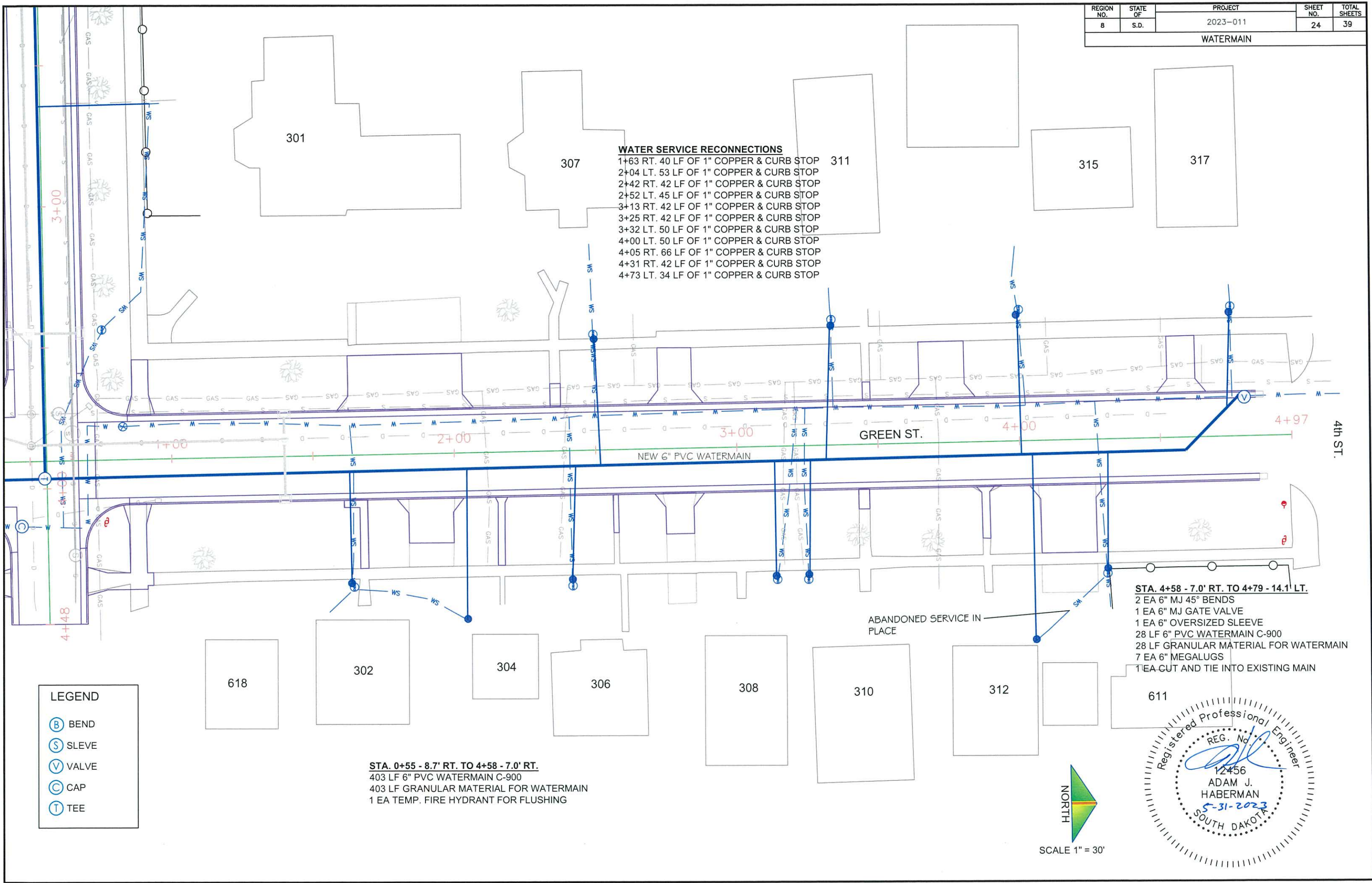

WATER SERVICE RECONNECTIONS
 1+63 RT. 40 LF OF 1" COPPER & CURB STOP
 2+04 LT. 53 LF OF 1" COPPER & CURB STOP
 2+42 RT. 42 LF OF 1" COPPER & CURB STOP
 2+52 LT. 45 LF OF 1" COPPER & CURB STOP
 3+13 RT. 42 LF OF 1" COPPER & CURB STOP
 3+25 RT. 42 LF OF 1" COPPER & CURB STOP
 3+32 LT. 50 LF OF 1" COPPER & CURB STOP
 4+00 LT. 50 LF OF 1" COPPER & CURB STOP
 4+05 RT. 66 LF OF 1" COPPER & CURB STOP
 4+31 RT. 42 LF OF 1" COPPER & CURB STOP
 4+73 LT. 34 LF OF 1" COPPER & CURB STOP

STA. 4+58 - 7.0' RT. TO 4+79 - 14.1' LT.
 2 EA 6" MJ 45° BENDS
 1 EA 6" MJ GATE VALVE
 1 EA 6" OVERSIZED SLEEVE
 28 LF 6" PVC WATERMAIN C-900
 28 LF GRANULAR MATERIAL FOR WATERMAIN
 7 EA 6" MEGALUGS
 1 EA CUT AND TIE INTO EXISTING MAIN

STA. 0+55 - 8.7' RT. TO 4+58 - 7.0' RT.
 403 LF 6" PVC WATERMAIN C-900
 403 LF GRANULAR MATERIAL FOR WATERMAIN
 1 EA TEMP. FIRE HYDRANT FOR FLUSHING

LEGEND

(B)	BEND
(S)	SLEVE
(V)	VALVE
(C)	CAP
(T)	TEE

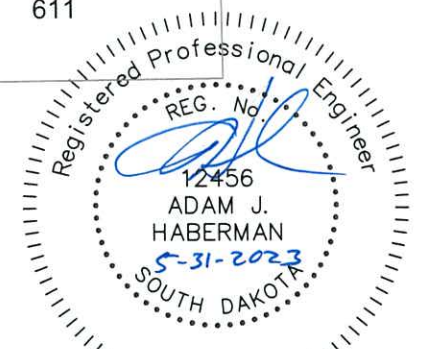

ABANDONED SERVICE IN PLACE

4th ST.

GREEN ST.

301

307

311

315

317

618

302

304

306

308

310

312

611

3+00

2+00

3+00

4+00

4+97

4+48

LEGEND

- (B) BEND
- (S) SLEVE
- (V) VALVE
- (C) CAP
- (T) TEE

STA. 0+55 - 8.7' RT. TO 4+58 - 7.0' RT.
 403 LF 6" PVC WATERMAIN C-900
 403 LF GRANULAR MATERIAL FOR WATERMAIN
 1 EA TEMP. FIRE HYDRANT FOR FLUSHING

STA. 4+58 - 7.0' RT. TO 4+79 - 14.1' LT.
 2 EA 6" MJ 45° BENDS
 1 EA 6" MJ GATE VALVE
 1 EA 6" OVERSIZED SLEEVE
 28 LF 6" PVC WATERMAIN C-900
 28 LF GRANULAR MATERIAL FOR WATERMAIN
 7 EA 6" MEGALUGS
 1 EA CUT AND TIE INTO EXISTING MAIN

ABANDONED SERVICE IN PLACE

4th ST.

GREEN ST.

301

307

311

315

317

618

302

304

306

308

310

312

611

3+00

2+00

3+00

4+00

4+97

4+48

LEGEND

- (B) BEND
- (S) SLEVE
- (V) VALVE
- (C) CAP
- (T) TEE

STA. 0+55 - 8.7' RT. TO 4+58 - 7.0' RT.
 403 LF 6" PVC WATERMAIN C-900
 403 LF GRANULAR MATERIAL FOR WATERMAIN
 1 EA TEMP. FIRE HYDRANT FOR FLUSHING

STA. 4+58 - 7.0' RT. TO 4+79 - 14.1' LT.
 2 EA 6" MJ 45° BENDS
 1 EA 6" MJ GATE VALVE
 1 EA 6" OVERSIZED SLEEVE
 28 LF 6" PVC WATERMAIN C-900
 28 LF GRANULAR MATERIAL FOR WATERMAIN
 7 EA 6" MEGALUGS
 1 EA CUT AND TIE INTO EXISTING MAIN

ABANDONED SERVICE IN PLACE

4th ST.

GREEN ST.

301

307

311

315

317

618

302

304

306

308

310

312

611

3+00

2+00

3+00

4+00

4+97

4+48

LEGEND

- (B) BEND
- (S) SLEVE
- (V) VALVE
- (C) CAP
- (T) TEE

STA. 0+55 - 8.7' RT. TO 4+58 - 7.0' RT.
 403 LF 6" PVC WATERMAIN C-900
 403 LF GRANULAR MATERIAL FOR WATERMAIN
 1 EA TEMP. FIRE HYDRANT FOR FLUSHING

STA. 4+58 - 7.0' RT. TO 4+79 - 14.1' LT.
 2 EA 6" MJ 45° BENDS
 1 EA 6" MJ GATE VALVE
 1 EA 6" OVERSIZED SLEEVE
 28 LF 6" PVC WATERMAIN C-900
 28 LF GRANULAR MATERIAL FOR WATERMAIN
 7 EA 6" MEGALUGS
 1 EA CUT AND TIE INTO EXISTING MAIN

ABANDONED SERVICE IN PLACE

4th ST.

GREEN ST.

301

307

311

315

317

618

302

304

306

308

310

312

611

3+00

2+00

3+00

4+00

4+97

4+48

LEGEND

- (B) BEND
- (S) SLEVE
- (V) VALVE
- (C) CAP
- (T) TEE

STA. 0+55 - 8.7' RT. TO 4+58 - 7.0' RT.
 403 LF 6" PVC WATERMAIN C-900
 403 LF GRANULAR MATERIAL FOR WATERMAIN
 1 EA TEMP. FIRE HYDRANT FOR FLUSHING

STA. 4+58 - 7.0' RT. TO 4+79 - 14.1' LT.
 2 EA 6" MJ 45° BENDS
 1 EA 6" MJ GATE VALVE
 1 EA 6" OVERSIZED SLEEVE
 28 LF 6" PVC WATERMAIN C-900
 28 LF GRANULAR MATERIAL FOR WATERMAIN
 7 EA 6" MEGALUGS
 1 EA CUT AND TIE INTO EXISTING MAIN

ABANDONED SERVICE IN PLACE

4th ST.

GREEN ST.

301

307

311

315

317

618

302

304

306

308

310

312

611

3+00

2+00

3+00

4+00

4+97

4+48

LEGEND

- (B) BEND
- (S) SLEVE
- (V) VALVE
- (C) CAP
- (T) TEE

STA. 0+55 - 8.7' RT. TO 4+58 - 7.0' RT.
 403 LF 6" PVC WATERMAIN C-900
 403 LF GRANULAR MATERIAL FOR WATERMAIN
 1 EA TEMP. FIRE HYDRANT FOR FLUSHING

STA. 4+58 - 7.0' RT. TO 4+79 - 14.1' LT.
 2 EA 6" MJ 45° BENDS
 1 EA 6" MJ GATE VALVE
 1 EA 6" OVERSIZED SLEEVE
 28 LF 6" PVC WATERMAIN C-900
 28 LF GRANULAR MATERIAL FOR WATERMAIN
 7 EA 6" MEGALUGS
 1 EA CUT AND TIE INTO EXISTING MAIN

ABANDONED SERVICE IN PLACE

4th ST.

GREEN ST.

301

307

311

315

317

618

302

304

306

308

310

312

611

3+00

2+00

3+00

4+00

4+97

4+48

LEGEND

- (B) BEND
- (S) SLEVE
- (V) VALVE
- (C) CAP
- (T) TEE

STA. 0+55 - 8.7' RT. TO 4+58 - 7.0' RT.
 403 LF 6" PVC WATERMAIN C-900
 403 LF GRANULAR MATERIAL FOR WATERMAIN
 1 EA TEMP. FIRE HYDRANT FOR FLUSHING

STA. 4+58 - 7.0' RT. TO 4+79 - 14.1' LT.
 2 EA 6" MJ 45° BENDS
 1 EA 6" MJ GATE VALVE
 1 EA 6" OVERSIZED SLEEVE
 28 LF 6" PVC WATERMAIN C-900
 28 LF GRANULAR MATERIAL FOR WATERMAIN
 7 EA 6" MEGALUGS
 1 EA CUT AND TIE INTO EXISTING MAIN

ABANDONED SERVICE IN PLACE

4th ST.

GREEN ST.

301

307

311

315

317

618

302

304

306

308

310

312

611

3+00

2+00

3+00

4+00

4+97

4+48

LEGEND

- (B) BEND
- (S) SLEVE
- (V) VALVE
- (C) CAP
- (T) TEE

STA. 0+55 - 8.7' RT. TO 4+58 - 7.0' RT.
 403 LF 6" PVC WATERMAIN C-900
 403 LF GRANULAR MATERIAL FOR WATERMAIN
 1 EA TEMP. FIRE HYDRANT FOR FLUSHING

STA. 4+58 - 7.0' RT. TO 4+79 - 14.1' LT.
 2 EA 6" MJ 45° BENDS
 1 EA 6" MJ GATE VALVE
 1 EA 6" OVERSIZED SLEEVE
 28 LF 6" PVC WATERMAIN C-900
 28 LF GRANULAR MATERIAL FOR WATERMAIN
 7 EA 6" MEGALUGS
 1 EA CUT AND TIE INTO EXISTING MAIN

ABANDONED SERVICE IN PLACE

4th ST.

GREEN ST.

301

307

311

315

317

618

302

304

306

308

310

312

611

3+00

2+00

3+00

4+00

4+97

4+48

LEGEND

- (B) BEND
- (S) SLEVE
- (V) VALVE
- (C) CAP
- (T) TEE

STA. 0+55 - 8.7' RT. TO 4+58 - 7.0' RT.
 403 LF 6" PVC WATERMAIN C-900
 403 LF GRANULAR MATERIAL FOR WATERMAIN
 1 EA TEMP. FIRE HYDRANT FOR FLUSHING

STA. 4+58 - 7.0' RT. TO 4+79 - 14.1' LT.
 2 EA 6" MJ 45° BENDS
 1 EA 6" MJ GATE VALVE
 1 EA 6" OVERSIZED SLEEVE
 28 LF 6" PVC WATERMAIN C-900
 28 LF GRANULAR MATERIAL FOR WATERMAIN
 7 EA 6" MEGALUGS
 1 EA CUT AND TIE INTO EXISTING MAIN

ABANDONED SERVICE IN PLACE

4th ST.

GREEN ST.

301

307

311

315

317

618

302

304

306

308

310

312

611

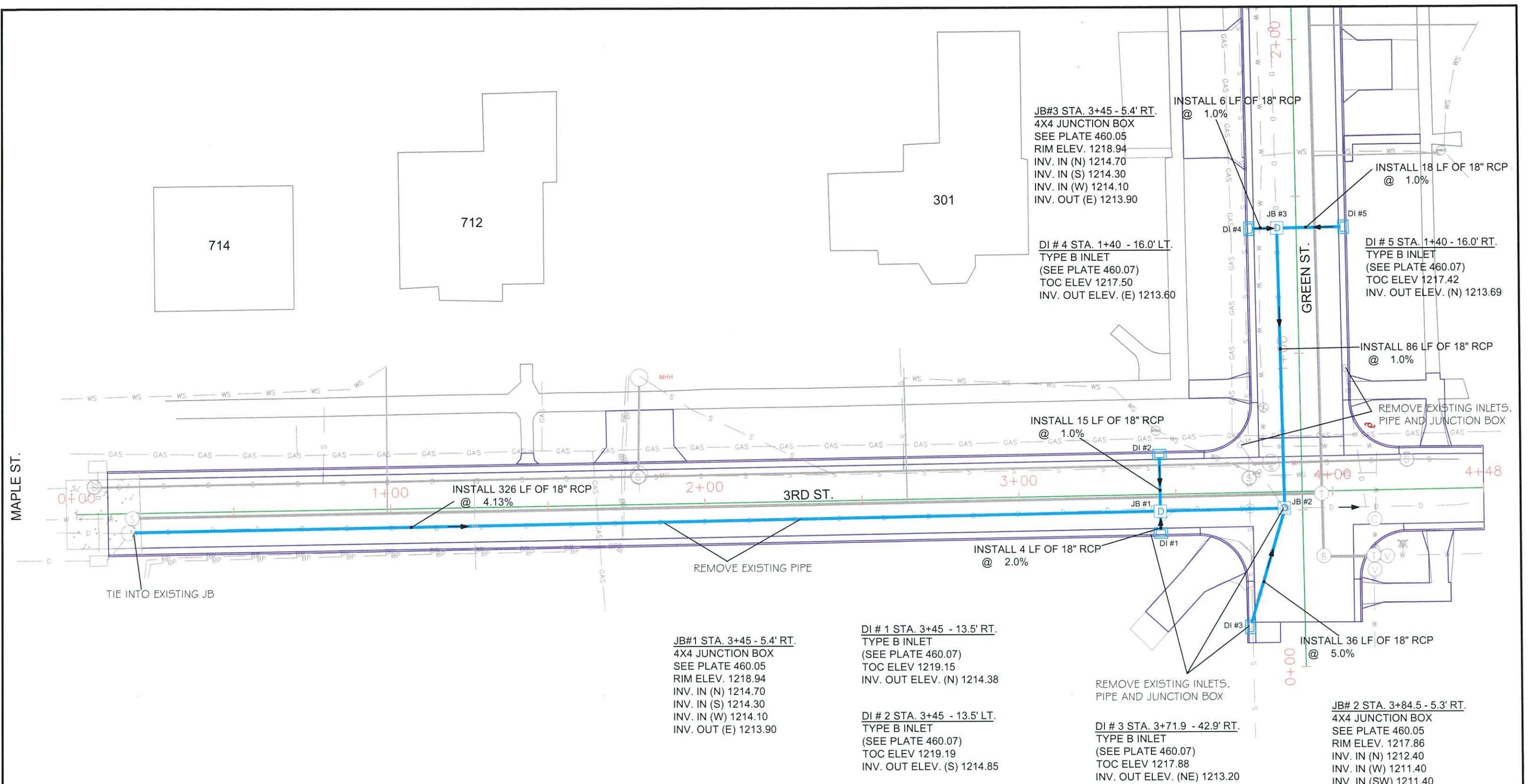

JB#3 STA. 3+45 - 5.4' RT.
 4X4 JUNCTION BOX
 SEE PLATE 460.05
 RIM ELEV. 1218.94
 INV. IN (N) 1214.70
 INV. IN (S) 1214.30
 INV. IN (W) 1214.10
 INV. OUT (E) 1213.90

DI # 4 STA. 1+40 - 16.0' LT.
 TYPE B INLET
 (SEE PLATE 460.07)
 TOC ELEV 1217.50
 INV. OUT ELEV. (E) 1213.60

INSTALL 18 LF OF 18" RCP
 @ 1.0%

DI # 5 STA. 1+40 - 16.0' RT.
 TYPE B INLET
 (SEE PLATE 460.07)
 TOC ELEV 1217.42
 INV. OUT ELEV. (N) 1213.69

INSTALL 86 LF OF 18" RCP
 @ 1.0%

REMOVE EXISTING INLETS,
 PIPE AND JUNCTION BOX

INSTALL 15 LF OF 18" RCP
 @ 1.0%

INSTALL 4 LF OF 18" RCP
 @ 2.0%

INSTALL 36 LF OF 18" RCP
 @ 5.0%

JB#1 STA. 3+45 - 5.4' RT.
 4X4 JUNCTION BOX
 SEE PLATE 460.05
 RIM ELEV. 1218.94
 INV. IN (N) 1214.70
 INV. IN (S) 1214.30
 INV. IN (W) 1214.10
 INV. OUT (E) 1213.90

DI # 1 STA. 3+45 - 13.5' RT.
 TYPE B INLET
 (SEE PLATE 460.07)
 TOC ELEV 1219.15
 INV. OUT ELEV. (N) 1214.38

DI # 2 STA. 3+45 - 13.5' LT.
 TYPE B INLET
 (SEE PLATE 460.07)
 TOC ELEV 1219.19
 INV. OUT ELEV. (S) 1214.85

REMOVE EXISTING INLETS,
 PIPE AND JUNCTION BOX

DI # 3 STA. 3+71.9 - 42.9' RT.
 TYPE B INLET
 (SEE PLATE 460.07)
 TOC ELEV 1217.88
 INV. OUT ELEV. (NE) 1213.20

JB# 2 STA. 3+84.5 - 5.3' RT.
 4X4 JUNCTION BOX
 SEE PLATE 460.05
 RIM ELEV. 1217.86
 INV. IN (N) 1212.40
 INV. IN (W) 1211.40
 INV. IN (SW) 1211.40
 INV. OUT (E) 1210.89

MAPLE ST.

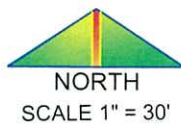
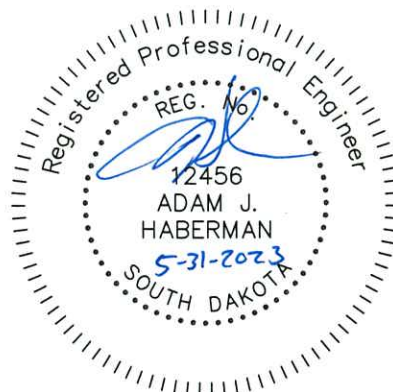

REGION NO.	STATE OF	PROJECT	SHEET NO.	TOTAL SHEETS
8	S.D.	2023-011	25	39
STORM SEWER				

30" CONCRETE CURB AND GUTTER

N.T.S

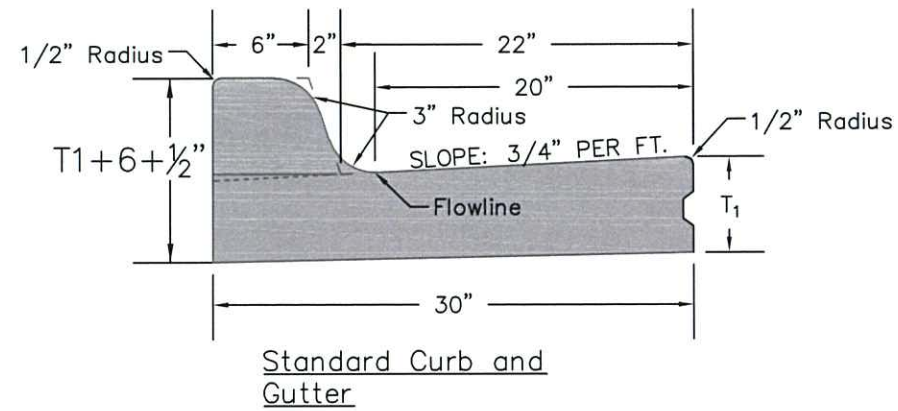

TYPE	T1 INCHES	CU. YD PER LIN. FT.
B66	6"	0.055
B67	7"	0.063
B68	8"	0.071
B68.5	8.5"	0.074
B69	9"	0.078
B69.5	9.5"	0.082
B610	10"	0.086
B610.5	10.5"	0.090
B611	11"	0.094
B611.5	11.5"	0.098
B612	12.0"	0.102

1/2" Preformed Expansion Joint Fillers shall be placed, Transversely in the Curb & Gutter as follows:

- (1) At each junction of Radius return Curb & Gutter and the Curb & Gutter which is parallel to the project centerline.
- (2) At each junction with existing Concrete Curb or Concrete Curb & Gutter
- (3) At each junction with existing sidewalk, to the depth of the sidewalk.
- (4) At a maximum of 195 L.F. apart, measured along the face of the Curb & Gutter.

1/2" Preformed Expansion Joint Filler shall be placed, Longitudinally, along the backface of the Curb, to the depth of the sidewalk, where such backface of Curb is adjacent to an existing Concrete Sidewalk.

Weakened Plane Joints shall be constructed at Approx. 10' intervals. The joints shall be constructed to a minimum depth of one inch by scoring with a tool which coincide with pavement joints leave the corners rounded and insure a free movement of the Concrete at the joint.

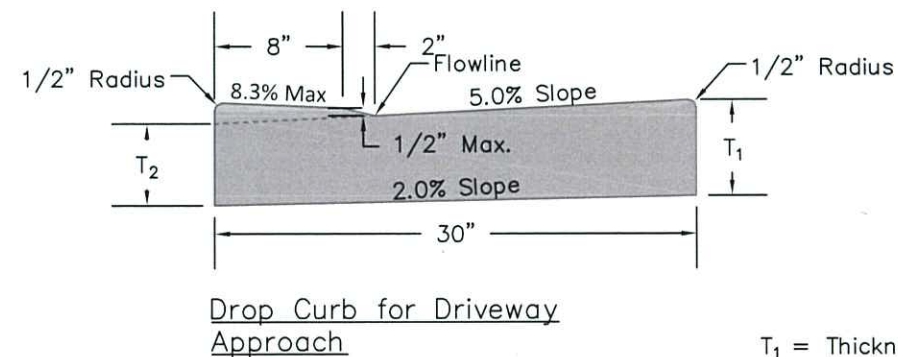
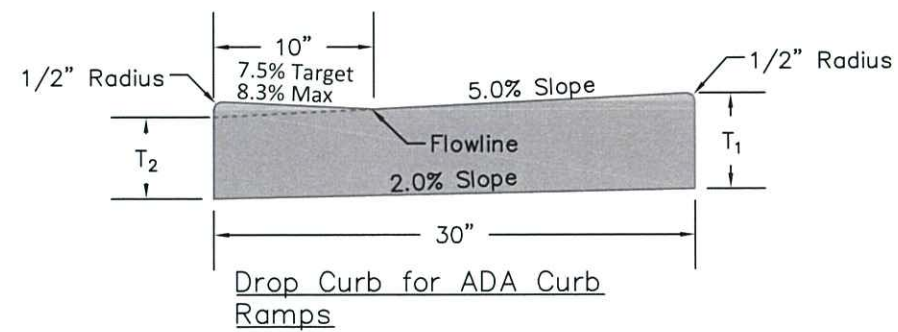

T₁ = Thickness shall be equal to the depth of the adjacent pavement but not less than 6"
T₂ = T₁ - 7/8"

GENERAL NOTES:

- 1) On PCC pavement a keyway longitudinal joint with **tie bars shall be used** when curb and gutter is poured separately.
- 2) Curb and gutter shall be constructed using M-6 concrete unless monolithically constructed with the adjacent pavement. In monolithic paving, concrete mix for the curb and gutter may be the same as the adjacent concrete pavement.
- 3) The curb transition length at ADA curb ramps will be dependent on the type of curb ramp being installed. The plans should call out the length of the transitions. Refer to plate 651.02 for additional curb transition information.

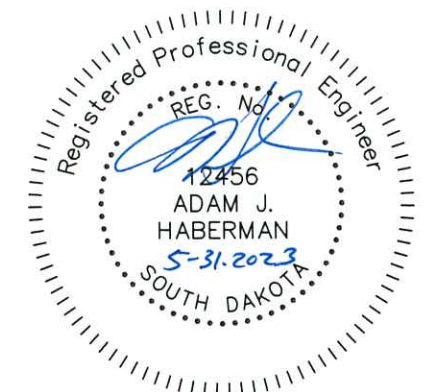

REGION NO.	STATE OF	PROJECT	SHEET NO.	TOTAL SHEETS
8	S.D.	2023-011	27	39
DETAILS				

Sanitary Sewer Manhole

Bedding and Backfill Requirements For 4" to 60" Sanitary Sewer Pipe

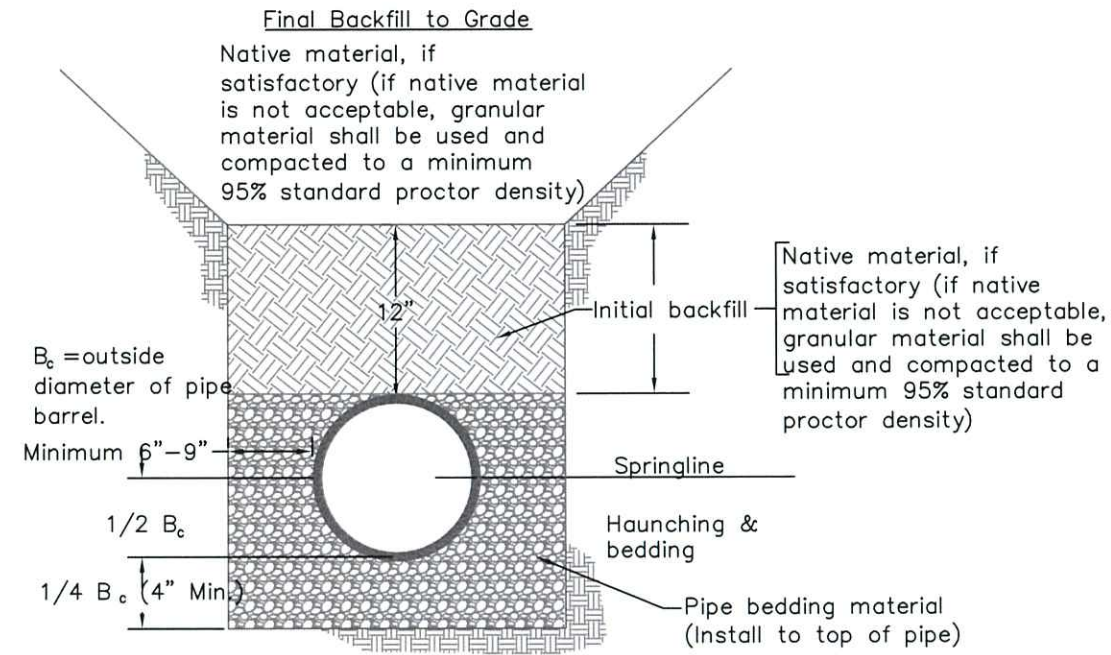

Pipe bedding material to be hand tamped or shovel sliced around haunches.

Undisturbed soil for base (see Note 1)

Note:

1. If base is unstable, trench shall be undercut and stabilized with trench stabilization material. Specifications as per manufacturer's recommendations and A.S.T.M. C12.
2. Bedding Material
 95% Passing 3/4" sieve
 95% Retained #4 sieve
 (Clean angular, well-graded, crushed rock. Pea rock may be used for sanitary sewer service lines.)
3. The required bedding material under the bottom of the pipe shall be installed prior to pipe installation.

Manhole cover per standard specifications for sanitary sewer construction.

Manhole frame to be Neenah R1772 or engineer approved equal.

Neenah R1712 (with bolt-down cover plate) or engineer approved equal will be required in all easement areas outside of the street R.O.W. unless otherwise directed by the city engineer

Neenah R1713 manhole frame shall be installed where manholes are located in concrete pavement thicker than 6 inches.

EJ three bolt compression frame and cover or engineer approved equal shall be installed in specified areas outside of street R.O.W. with hard surfacing.

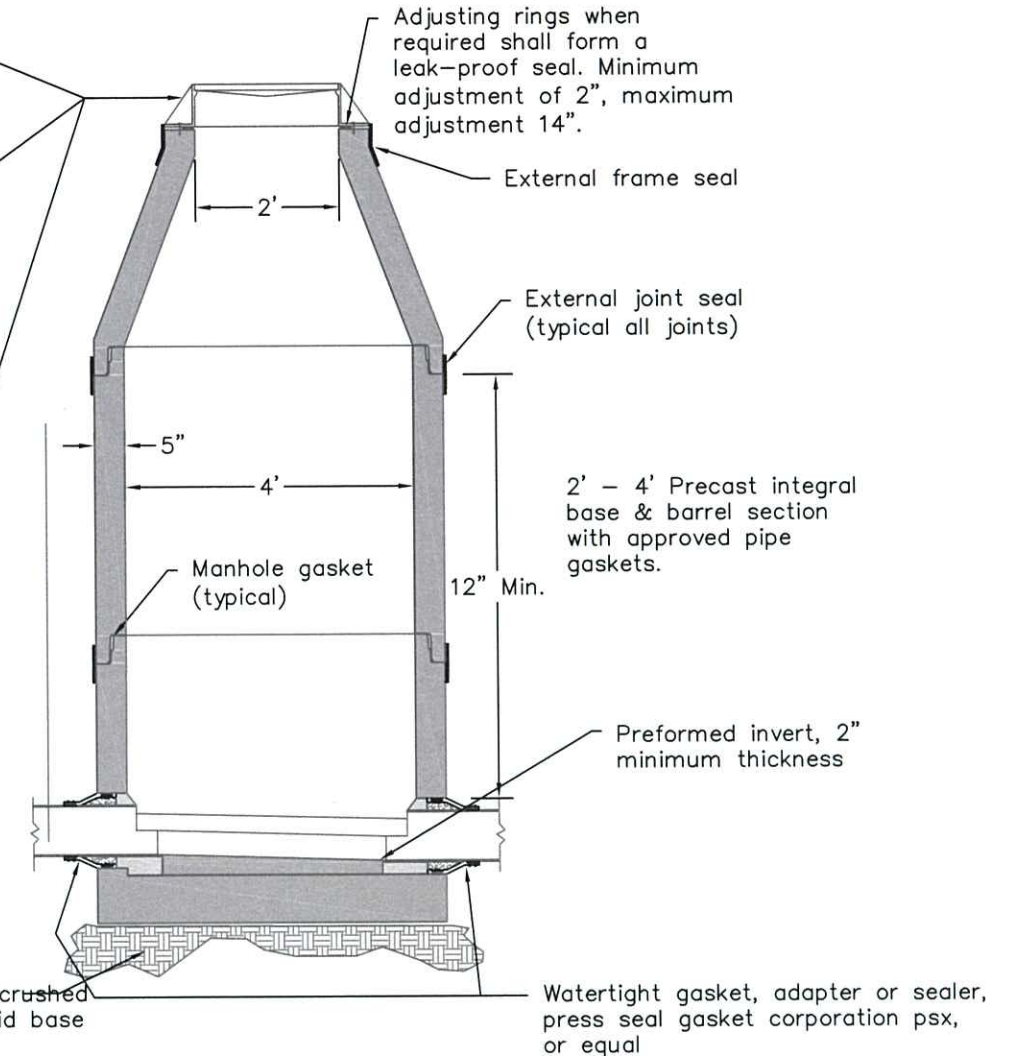

Native material or crushed rock to form a solid base

Watertight gasket, adapter or sealer, press seal gasket corporation psx, or equal

Precast flat top section typical joint sealed with manhole gasket (typical)

Typical Precast & Flat Top Section (where specified)

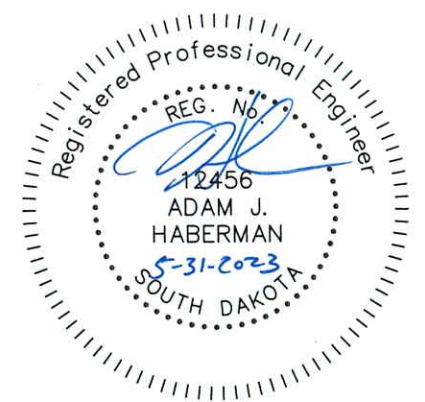
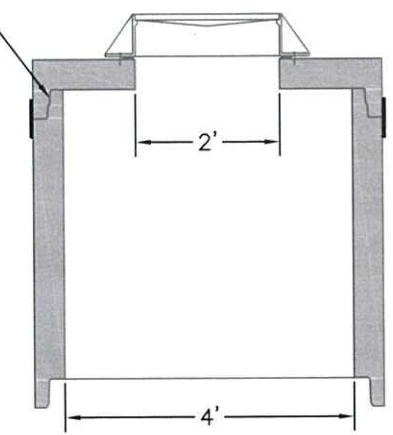

Hydrant Connection

NOTE: THRUST BLOCKS ARE REQUIRED AT ALL ABRUPT CHANGES IN DIRECTION, TEES, BENDS, DEAD ENDS AND HYDRANTS. ALL BLOCKS ARE TO BE POURED AND AGAINST SOLID UNDISTURBED TRENCH WALL, UNLESS OTHERWISE NOTED BY THE ENGINEER. BREAK BOND BETWEEN POURED CONCRETE THRUST BLOCKS AND PIPE FITTINGS WITH TAR PAPER ETC. LENGTH OF BEARING SURFACE SHALL BE BETWEEN 1 AND 2 TIMES THE HEIGHT OF BEARING SURFACE.

C'S OF PIPE & THRUST BLOCK SHOULD COINCIDE

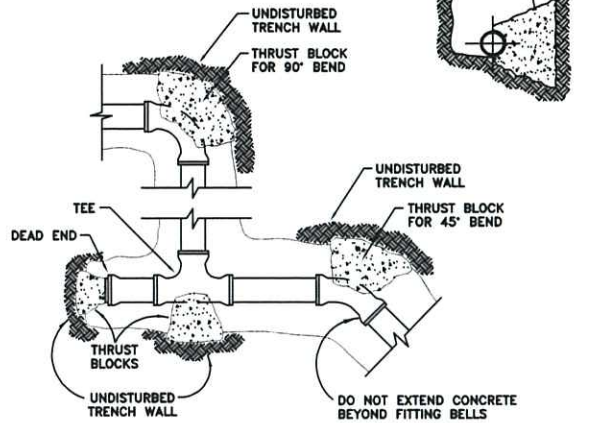

SDF

PIPE SIZE	DEAD END OR TEE	90° BEND	45° BEND	22 1/2° BEND	11 1/4° BEND
12"	11 1/2	16	9	4 1/2	2 1/2
10"	8	11	6	3	1 1/2
8"	5	7	4	2	1
6"	3	4	2	1	1/2
4"	1 1/2	1 1/2	1	1/2	-

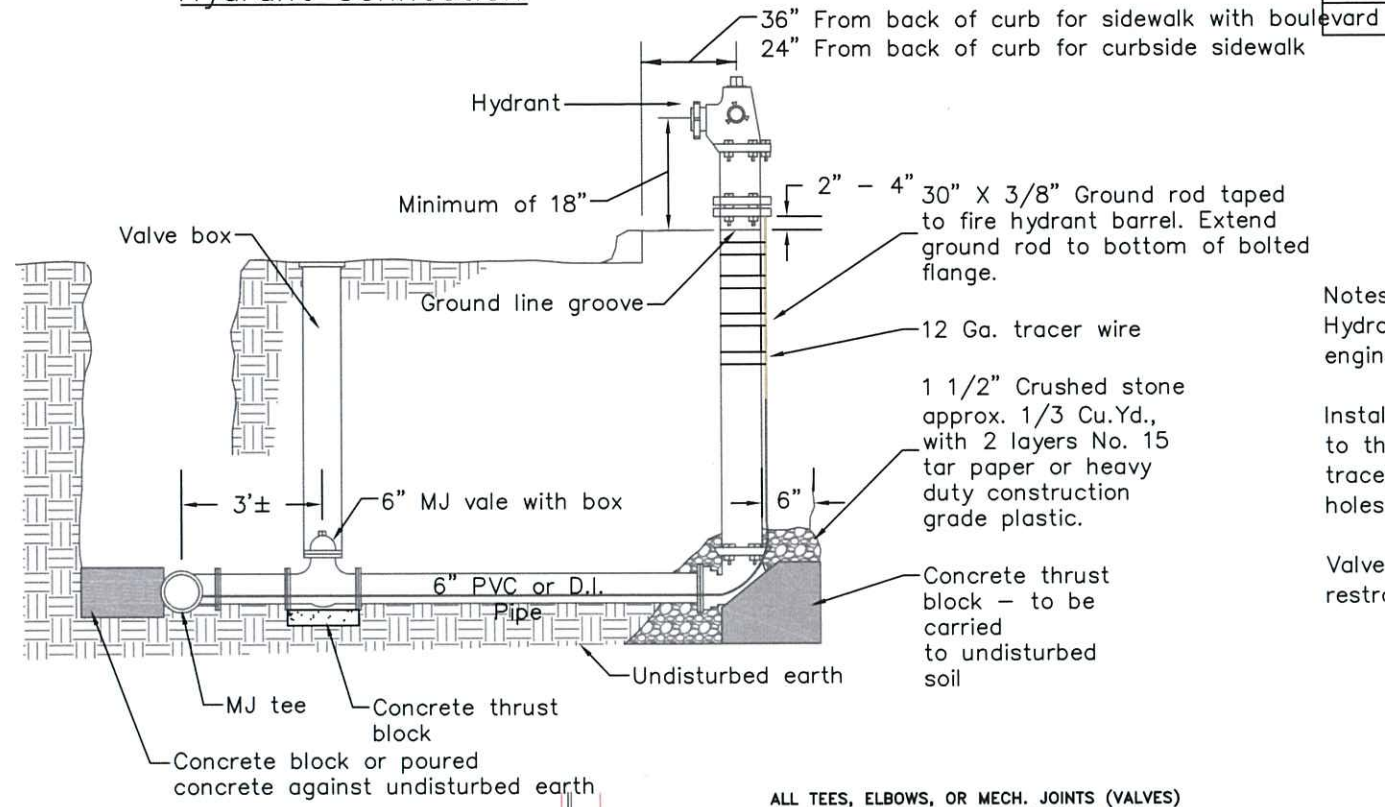

Notes:
Hydrant grade to be given by engineers.

Install polywrap on fire hydrant barrel to the ground surface before installing tracer wire system. Do not cover weep holes with poly wrap.

Valve on fire hydrant lateral shall be restrained.

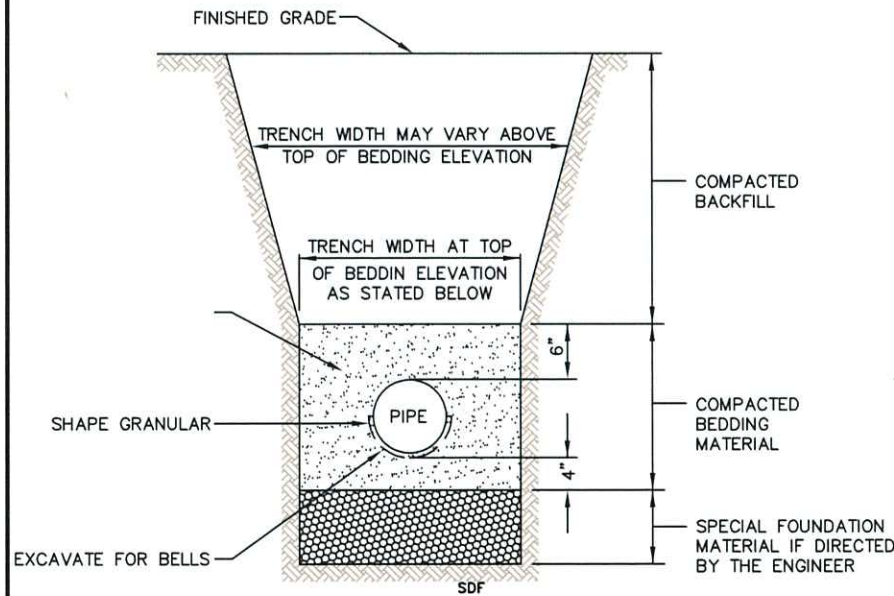

WHERE TRENCH WALLS BELOW THE TOP OF THE BEDDING MATERIAL ARE VERTICAL AND FREE-STANDING, MINIMUM TRENCH WIDTHS ARE AS FOLLOWS:

PIPE SIZE	MINIMUM TRENCH WIDTH
8"	24"
10"	26"
12"	28"
15"	32"
18"	36"
21"	40"
24"	43"

DETAIL OF BEDDING & BACKFILL

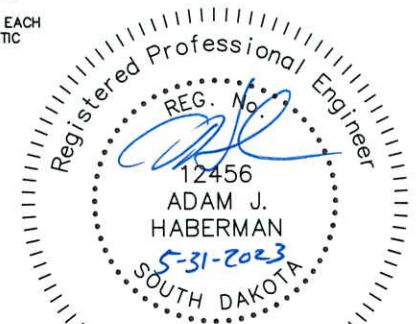
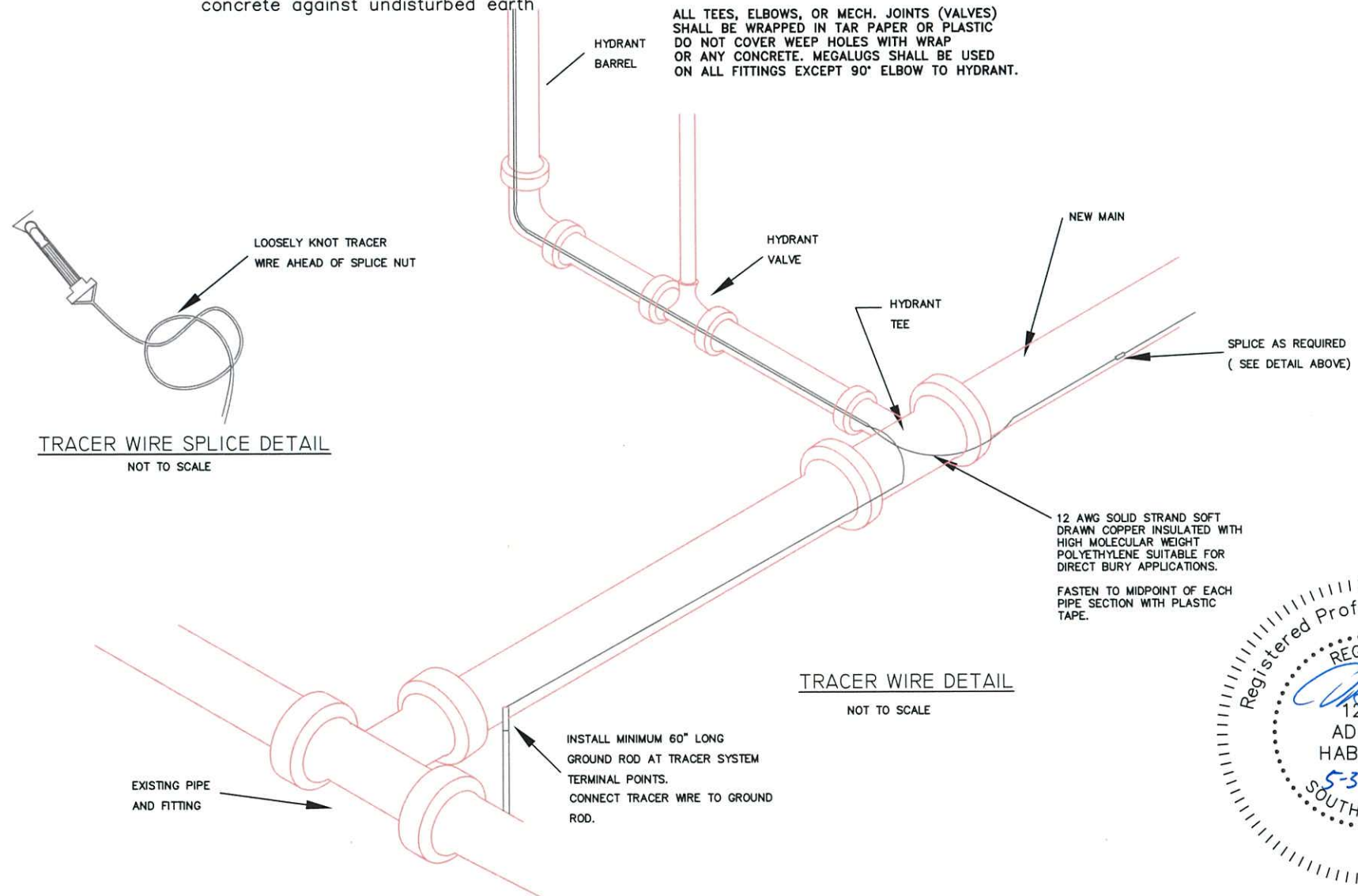
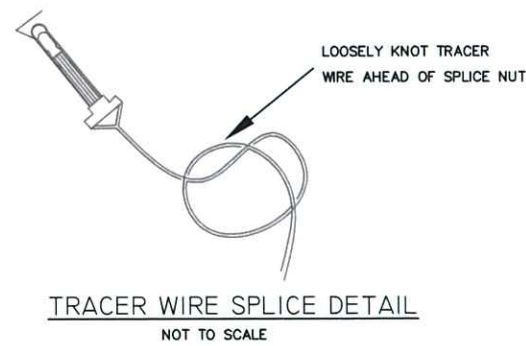

Estimated Quantities			
Item	Unit	Constant	Variable
* Class M6 concrete	CuYds	0.27	0.32V
Reinforcement-conc. masonry	LBS	28	---

* Constant shall be reduced for the appropriate pipe or combination of pipes, thus; 12" Dia.=0.03 C.Y., 15" Dia.=0.04 C.Y., 18" Dia.=0.05 C.Y., 24" Dia.=0.09 C.Y.

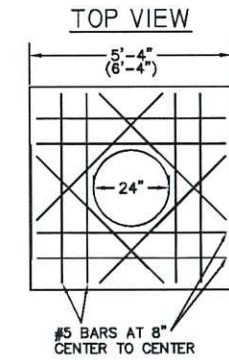
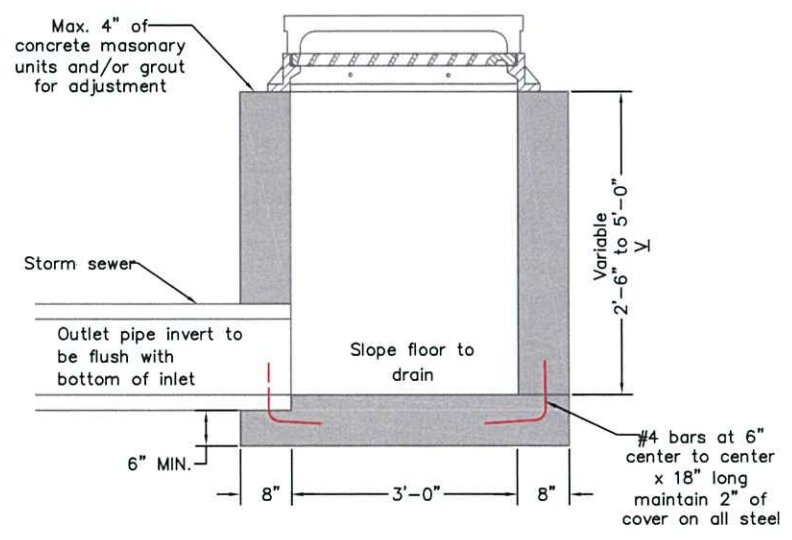
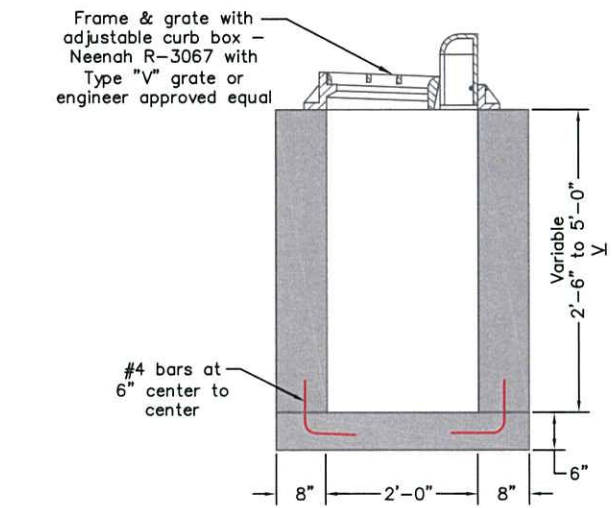

GENERAL NOTES
 USE SOUTH DAKOTA STANDARD SPECIFICATIONS FOR ROADS AND BRIDGES, LATEST EDITION, AND REQUIRED PROVISIONS, SUPPLEMENTAL SPECIFICATIONS AND/OR SPECIAL PROVISIONS AS INCLUDED IN THE PROPOSAL.
 ALL REINFORCING STEEL SHALL CONFORM TO A.S.T.M. A615, GRADE 60.
 ALL REINFORCING STEEL SHALL BE CUT AND/OR BENT IN THE FIELD TO MAINTAIN A MINIMUM OF 2" COVER ON ALL REINFORCING STEEL.
 NO VERTICAL CONSTRUCTION JOINTS ARE ALLOWED.
 ALL CONC. SHALL BE CLASSED M-6.
 UNIT STRESSES: CONCRETE $F_c = 1600$ P.S.I.
 REINFORCING STEEL $F_s = 20,000$ P.S.I.
 TOP OF MANHOLE COVER TO BE SET FLUSH WITH FINISHED SURFACE ELEVATION.

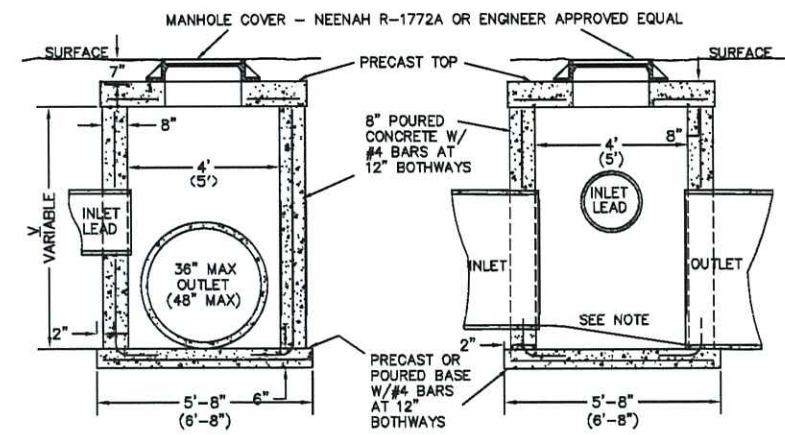

SIDE VIEWS

ITEM	UNIT	4' X 4' JCT. BOX		5' X 5' JCT. BOX	
		CONSTANT	VARIABLE	CONSTANT	VARIABLE
* CLASS M6 CONCRETE	CUYDS	1.29	0.46V	1.93	0.56V
REINFORCEMENT-CONC. MASONRY	LBS	103	23V	131	35V
MANHOLE RIM & COVER-AS SPECIFIED	EACH	1	---	1	---

* CONSTANT SHALL BE REDUCED FOR THE APPROPRIATE PIPE OR COMBINATION OF PIPES, THUS:
 12" DIA.=0.03 C.Y., 15" DIA.=0.04 C.Y., 18" DIA.=0.05 C.Y., 21" DIA.=0.07 C.Y., 24" DIA.=0.09 C.Y.,
 27" DIA.=0.11 C.Y., 30" DIA.=0.14 C.Y., 33" DIA.=0.17 C.Y., 36" DIA.=0.20 C.Y., 42" DIA.=0.26 C.Y.,
 48" DIA.=0.34 C.Y.

NOTES:
 COVER REINFORCEMENT REQUIRES 12-#5 BARS 5'(6') LONG TO BE PLACED AS SHOWN.
 2" FROM CIRCULAR OPENING AND 8" CENTER TO CENTER AT A DEPTH OF 8" W/MIN. COVER THICKNESS OF 8".
 FLOOR OF JCT. BOX TO BE FINISHED IN SUCH A MANNER TO INSURE UNINTERRUPTED FLOW THRU THE BOX.
 WHEN PIPE SIZES DIFFER THRU JCT. BOX, TOP OF PIPE TO MATCH WHEN POSSIBLE.
 () INDICATES SPECIFICATIONS FOR A 5' X 5' JCT. BOX. MAXIMUM PIPE SIZE ALLOWED FOR 4' X 4' JCT. BOX IS 36" R.C.P. A 5' X 5' JCT. IS 48" R.C.P.
 VARIABLE DEPTH UP TO 8'

SPECIFICATION REFERENCE NO. 460



CITY OF SIOUX FALLS
 ENGINEERING DIVISION
 STANDARD STORM SEWER
 JUNCTION BOX TYPE I

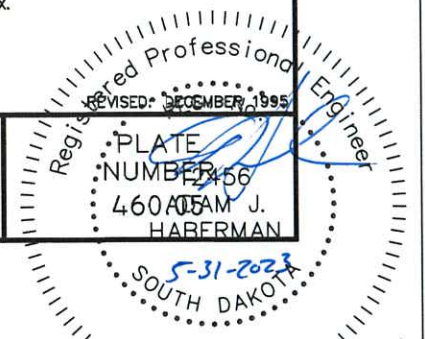

REGION NO.	STATE OF	PROJECT	SHEET NO.	TOTAL SHEETS
8	S.D.	2023-011	30	39
DETAILS				

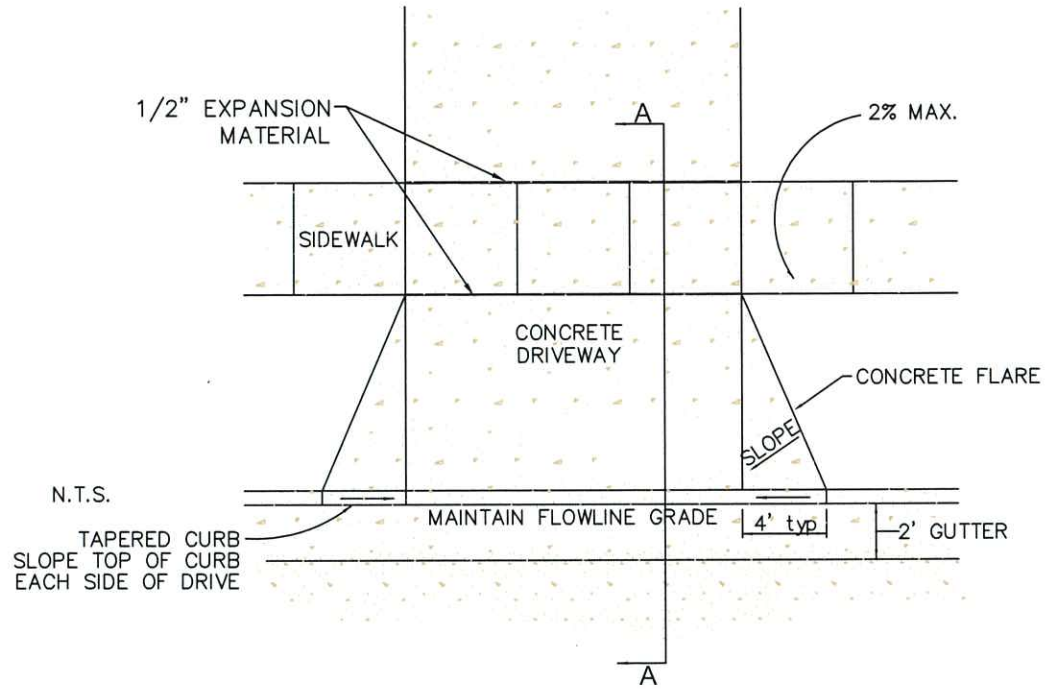

DETAIL FOR CONCRETE FLARES
AND TAPERED CURB AT DRIVEWAYS
N.T.S.

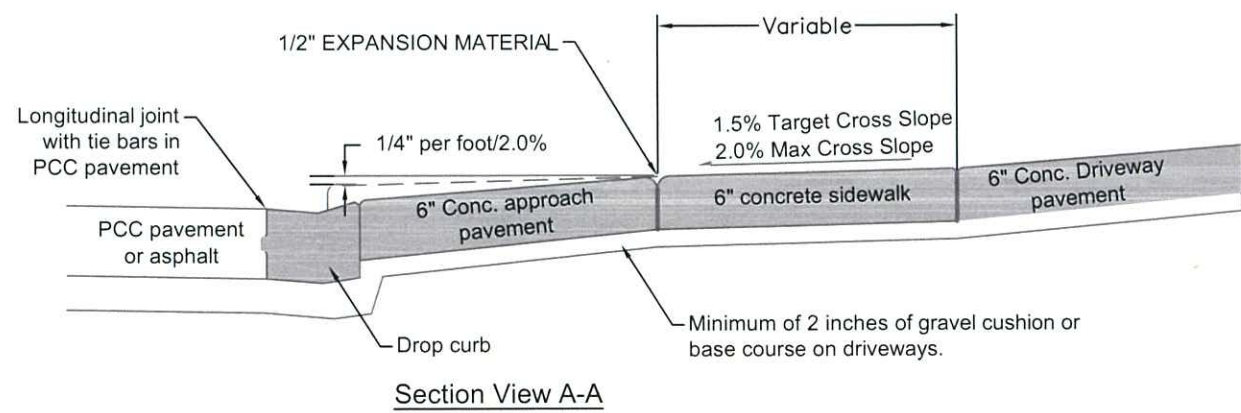
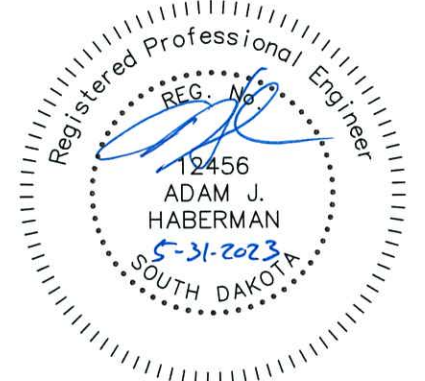

Section View A-A

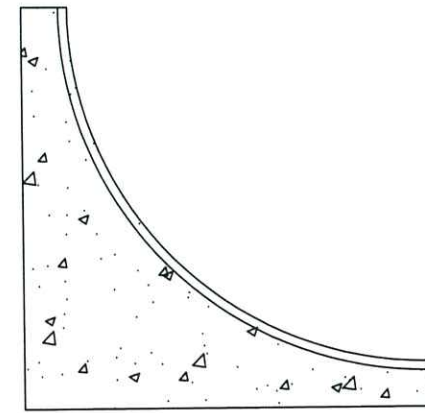

TYPICAL FILLET SECTION
N.T.S.

All Fillet sections to contain fiber mesh reinforced concrete.

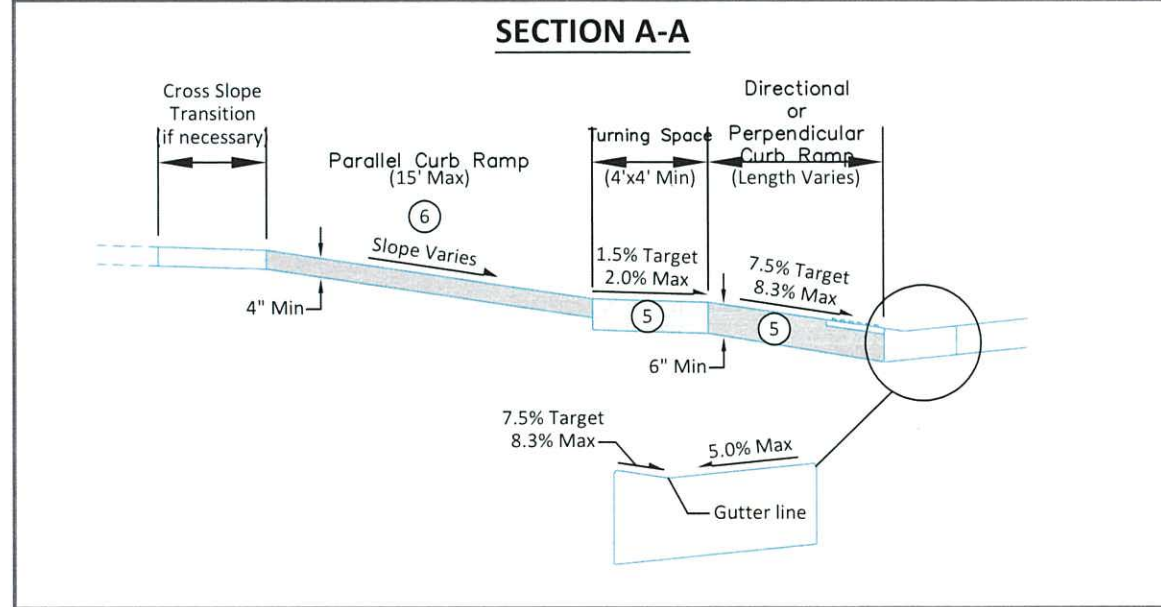
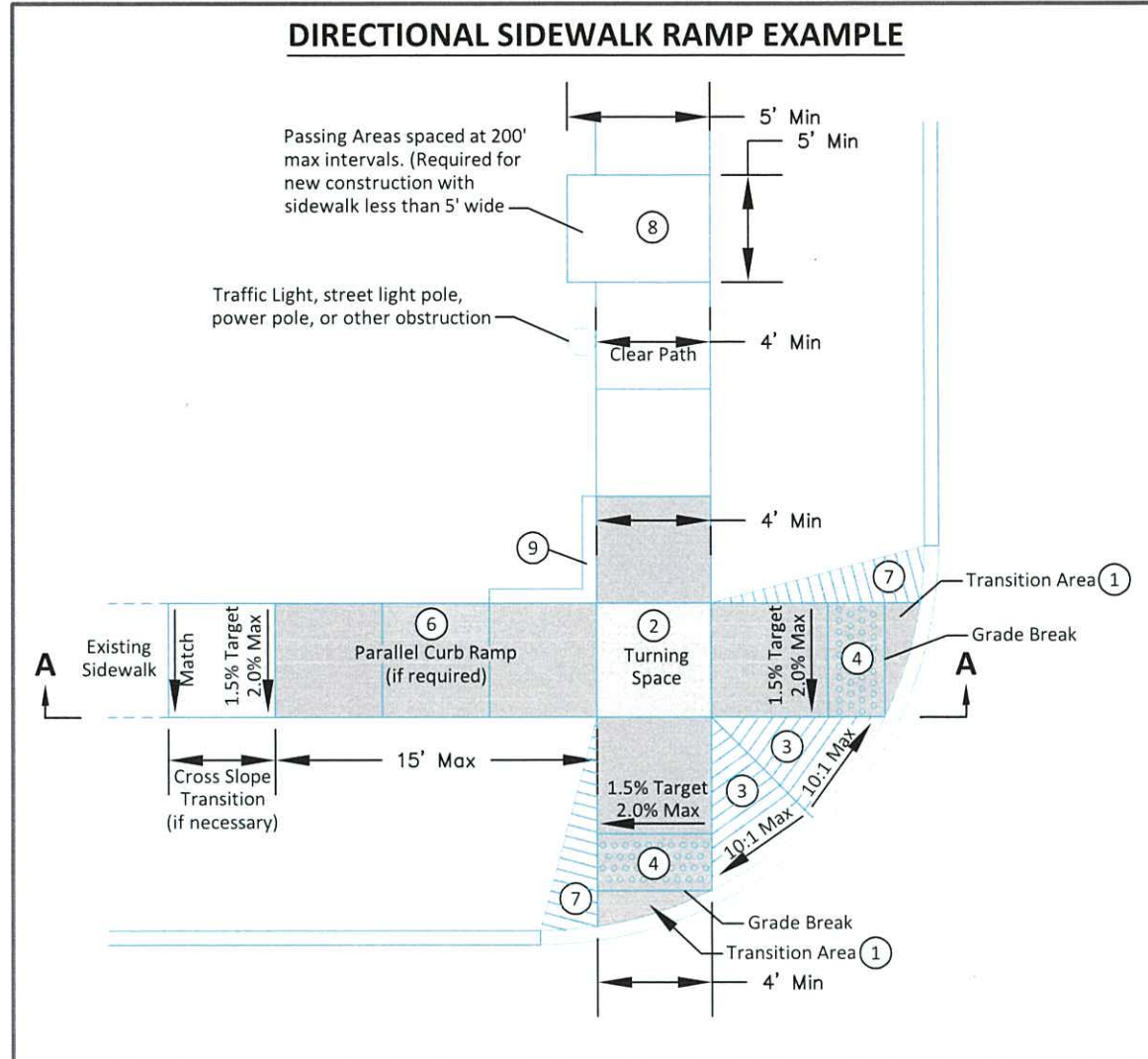
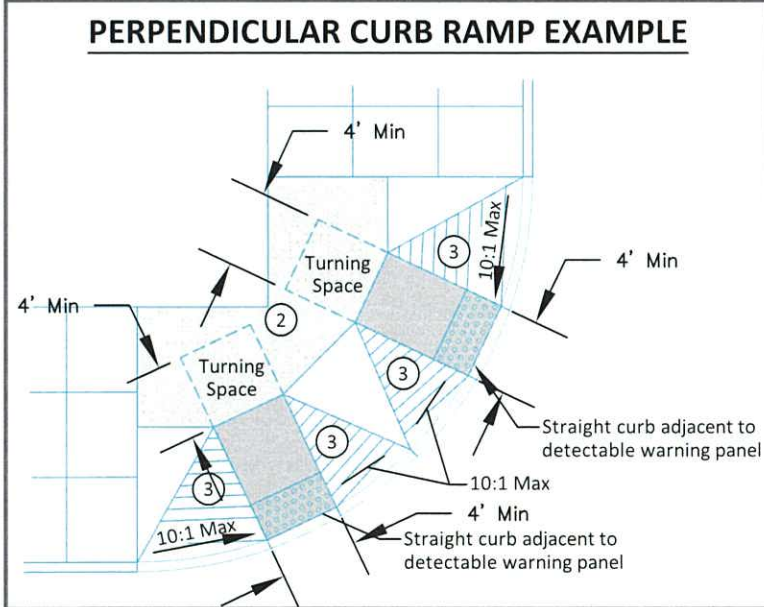
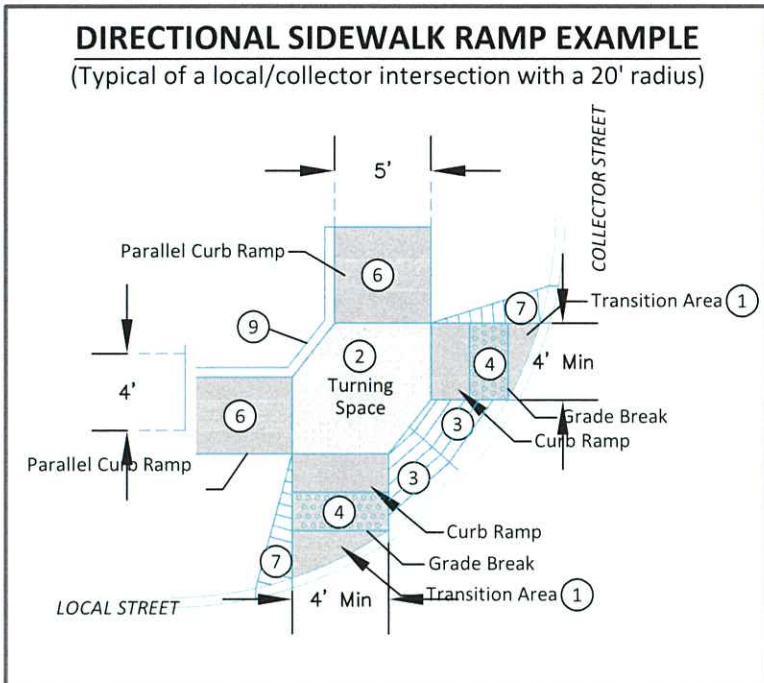
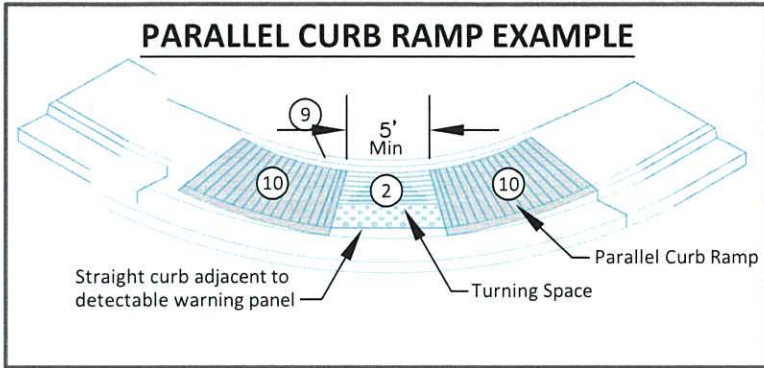

- NOTES:**
1. Transition from the the 2% maximum cross slope on the ramp and the pedestrian street crossing grade in this area. The maximum cross slope on the pedestrian street crossing (including the fillet or curb and gutter) is **2%** on stop or yield controlled legs and **5%** on uncontrolled or signalized legs.
 2. Minimum 4 feet by 4 feet. Target cross slope of 1.5% with a maximum cross slope of 2.0% in any direction. Where the turning space is confined at the back of sidewalk (example: 6" curb or building), the turning space shall be 4 foot by 5 foot minimum. The 5 foot dimension shall be in the direction of the ramp run. The grade change between the turning space and the curb ramp must be perpendicular to the direction of travel.
 3. Areas where the pedestrian circulation path crosses a curb ramp are considered flare sides. The maximum slope of the flare sides is 10%. Full curb height may not be able to be reestablished on flare slopes but as much curb height as possible should be reestablished.
 4. Provide a minimum 2 foot width of detectable warning surfaces in the direction of pedestrian travel across the full width of the curb ramp or turning space, exclusive of curbs or flares. Orient domes in the direction of pedestrian travel unless otherwise stated in plans.
 5. The concrete in the turning space, curb ramp, and flare slope areas shall be a minimum thickness of 6 inches.
 6. If normal sidewalk elevation cannot be achieved with the perpendicular ramp between the street and turning space due to limited ramp length, provide a parallel ramp to make up the elevation difference between the turning space and the standard sidewalk. This parallel ramp shall not exceed 8.3% slope. However, the length of the ramp is not required to exceed 15 feet, regardless of slope. The minimum sidewalk thickness for the parallel ramp in this area is 4 inches.
 7. Install a 2 foot taper when additional sidewalk will not be located adjacent to the curb ramp.
 8. Depending on the conditions, a curb up to 6 inches high may need to be installed on the back of the turning space or adjoining sidewalk.
 9. The slope of curb ramp and adjacent curb is designed at 7.5% or less but shall not be steeper than 8.3% unless otherwise specified in the plans. The curb ramp is not required to exceed 15 feet, regardless of slope. The cross slope target is 1.5% with a maximum cross slope of 2.0%.

GENERAL NOTES:

The turning space, curb ramp, and detectable warning panel area will be paid for at the contact unit price for the corresponding concrete sidewalk bid item.

The detectable warning panel shall be measured and paid for to the nearest square foot. Payment shall include all costs for materials, labor, and equipment necessary for the installation of the detectable warning panels.

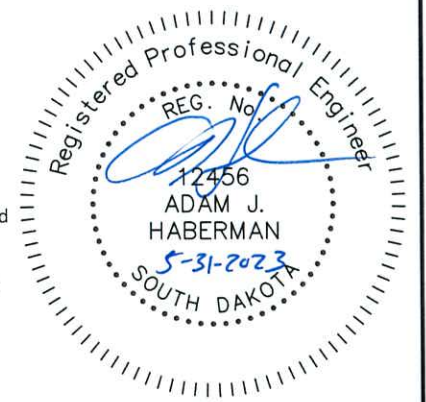

Revised: December 2016

 <p>CITY OF SIOUX FALLS ENGINEERING DIVISION ACCESSIBLE CURB RAMPS</p>	
<p>SPECIFICATION REFERENCE NO. 650</p>	<p>PLATE NUMBER 651.02</p>

**LONGITUDINAL CONSTRUCTION JOINT WITH TIE BARS
(DRILLED IN BARS)**

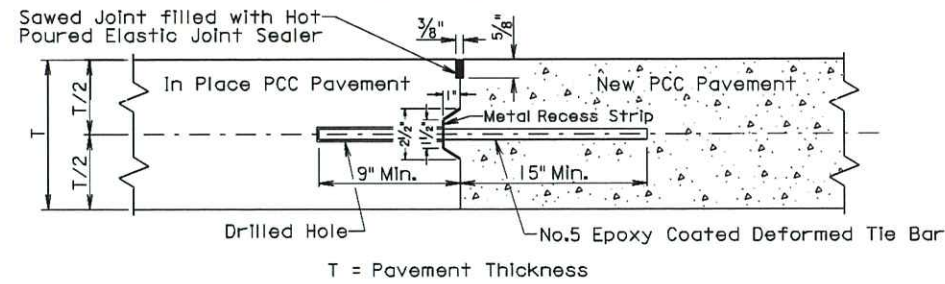

GENERAL NOTES:
 The tie bars shall be embedded a minimum depth of 9 inches into the In place PCC pavement and anchored with an epoxy resin adhesive.
 No.5 epoxy coated deformed tie bars shall be spaced 48" center to center for a female keyway or 30" center to center for a vertical face and male keyway. The keyway shown above is a female keyway.
 The tie bars shall be placed a minimum of 15 inches from existing transverse contraction joints.
 The keyway is optional and is not required. When concrete pavement is formed and a keyway is provided, a metal recess strip shall be used. When concrete pavement is slip formed, a metal recess strip is not required.
 The term "In Place PCC Pavement" in the above drawing indicates that the In place PCC pavement was placed on a previous project or current project.

**LONGITUDINAL CONSTRUCTION JOINT WITH TIE BARS
(INSERTED OR FORMED IN BARS)**

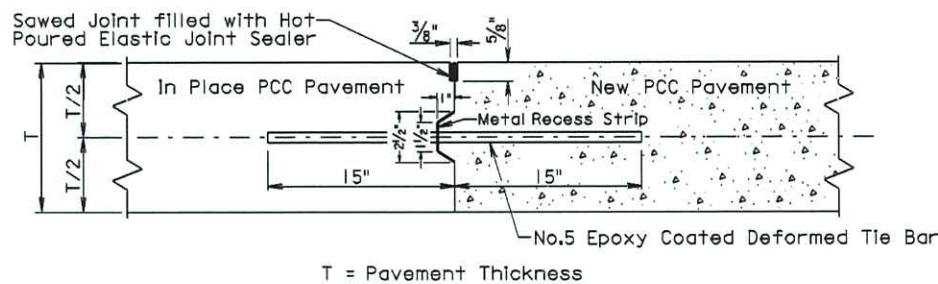

GENERAL NOTES:
 No.5 epoxy coated deformed tie bars shall be spaced 48" center to center for a female keyway or 30" center to center for a vertical face and male keyway. The keyway shown above is a female keyway.
 The tie bars shall be placed a minimum of 15 inches from existing transverse contraction joints.
 The keyway is optional and is not required. When concrete pavement is formed and a keyway is provided, a metal recess strip shall be used. When concrete pavement is slip formed, a metal recess strip is not required.
 The term "In Place PCC Pavement" in the above drawing indicates that the In place PCC pavement was placed on the current project.

September 14, 2001

S D D O T	PCC PAVEMENT LONGITUDINAL JOINTS WITH TIE BARS	PLATE NUMBER 380.10
		Sheet 1 of 2

Published Date: 4th Qtr. 2007

**SAWED LONGITUDINAL JOINT WITH TIE BARS
(POURED MONOLITHICALLY)**

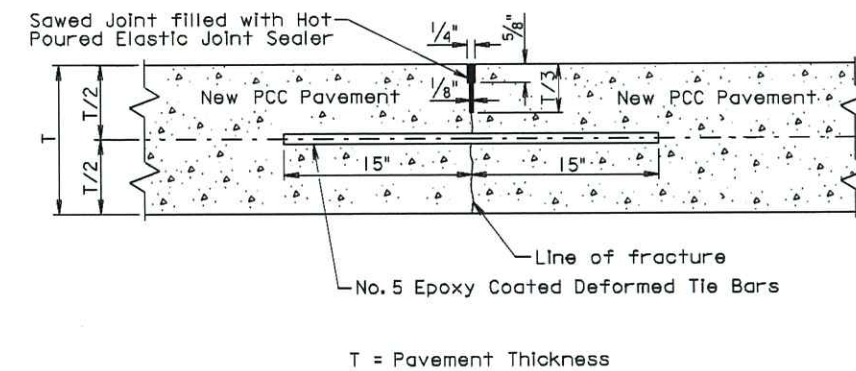

GENERAL NOTES:
 No.5 epoxy coated deformed tie bars shall be spaced 48 inches center to center.
 The tie bars shall be placed a minimum of 15 inches from the existing transverse contraction joints.
 The first saw cut to control cracking shall be a minimum of 1/3 the thickness of the pavement. Additional sawing for widening the saw cut to provide the width for the installation of the hot poured elastic joint sealer will be necessary.

September 14, 2001

S D D O T	PCC PAVEMENT LONGITUDINAL JOINTS WITH TIE BARS	PLATE NUMBER 380.10
		Sheet 2 of 2

Published Date: 4th Qtr. 2007

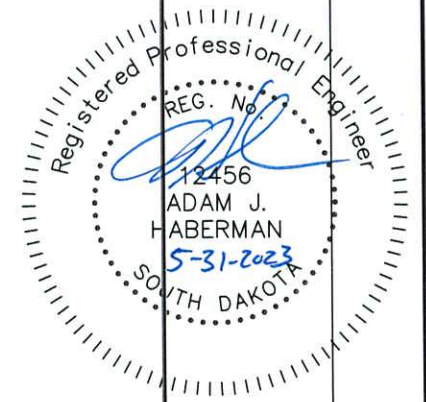

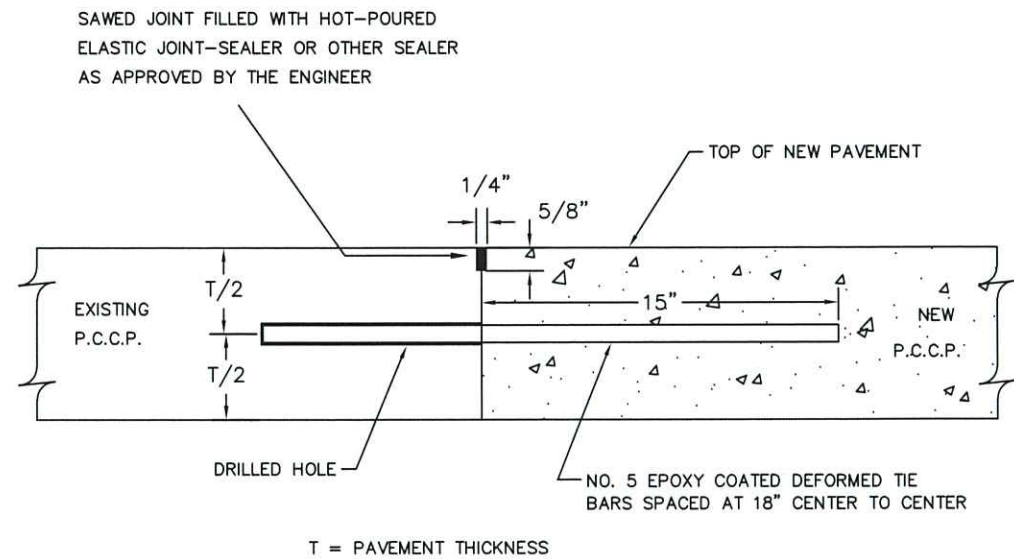

GENERAL NOTES

THE TIE BAR IS TO BE EMBEDDED A MINIMUM DEPTH OF 9 INCHES INTO THE EXISTING PAVEMENT BY UTILIZING AN EPOXY RESIN ADHESIVE.

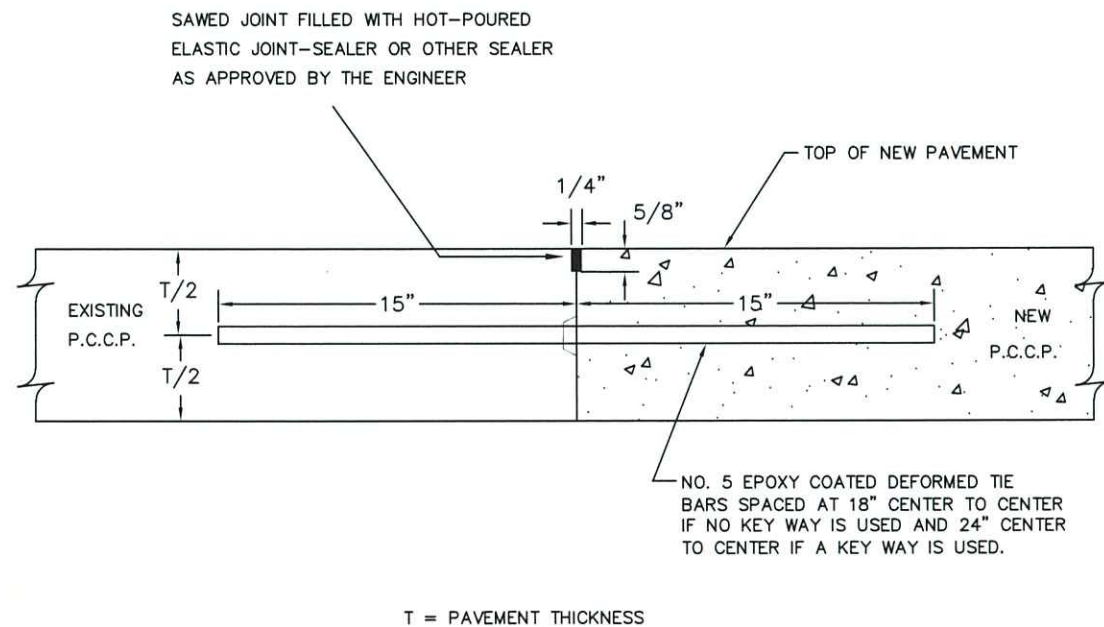

PCC PAVEMENT TRANSVERSE JOINTS WITH TIE BARS

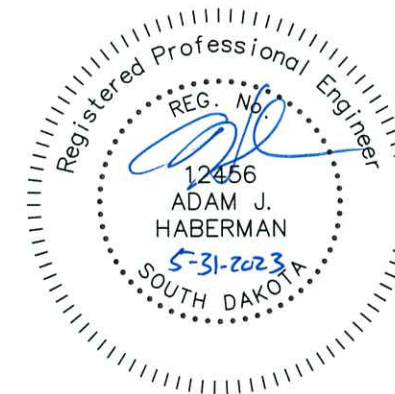
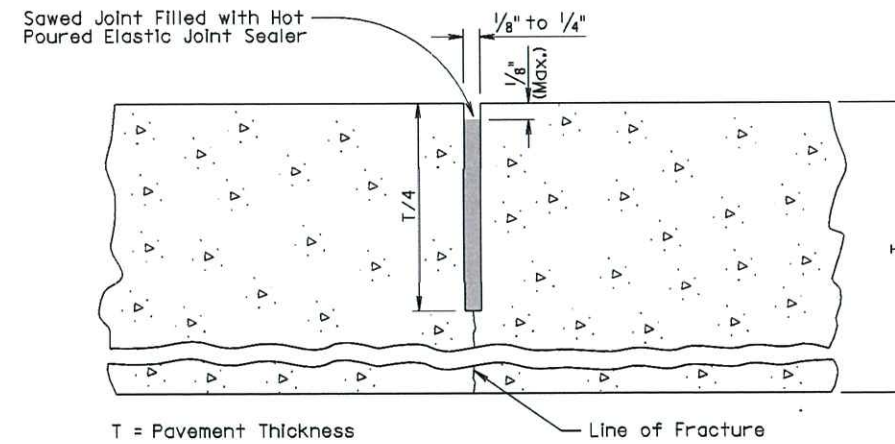

GENERAL NOTES:

The saw cut to control cracking shall be a minimum of 1/4 the thickness of the pavement. All hot poured elastic joint sealer material spilled on the surface of the concrete pavement shall be removed as soon as the material has cooled. The extent of removal of material shall be to the satisfaction of the Engineer. All costs for removal of the spilled joint sealer material shall be borne by the Contractor.

December 23, 2007

S D D O T	PCC PAVEMENT TRANSVERSE CONTRACTION JOINT WITH OR WITHOUT DOWEL BAR ASSEMBLY	PLATE NUMBER 380.03
	<i>Published Date: 4th Qtr. 2009</i>	Sheet 1 of 1

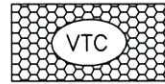

Vehicle Tracking Control

Definition:

A stone stabilized pad located at points of vehicular ingress and egress on a construction site.

Purposes:

To reduce the amount of mud transported onto public roads by motor vehicles or runoff.

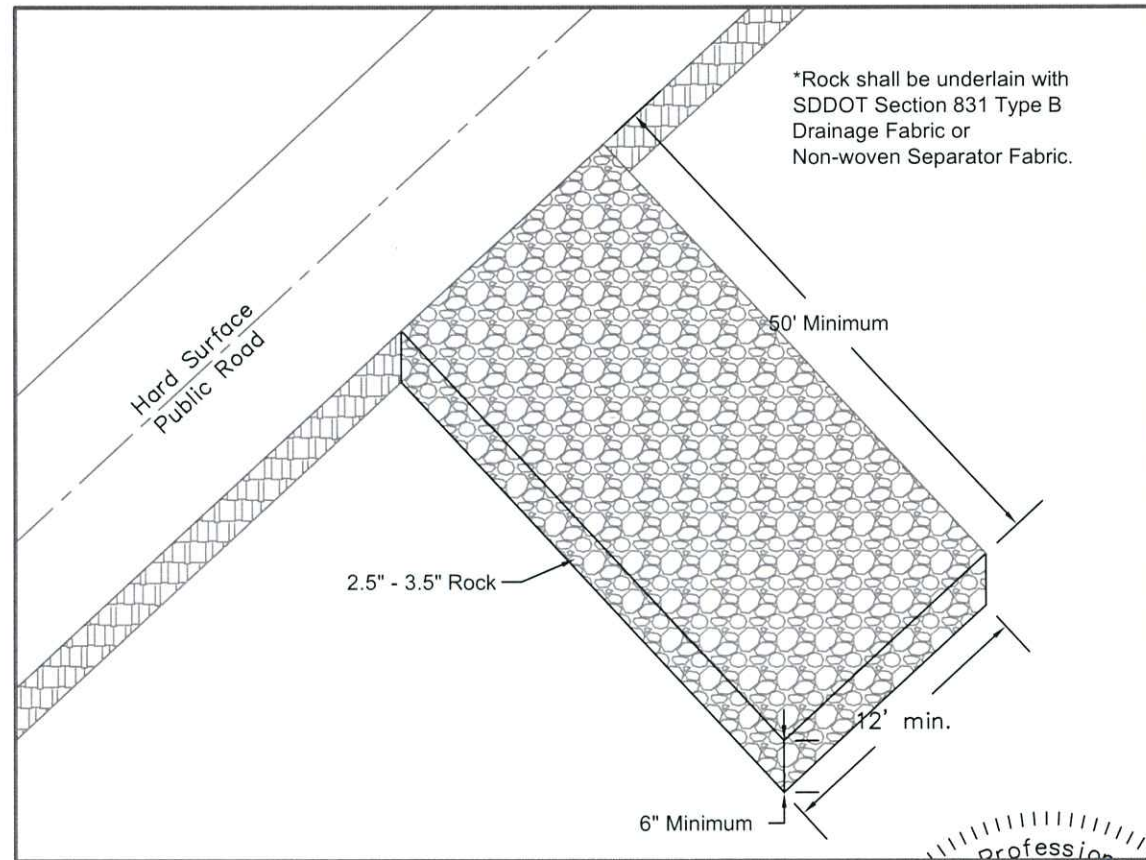

*Rock shall be underlain with SDDOT Section 831 Type B Drainage Fabric or Non-woven Separator Fabric.

50' Minimum

2.5" - 3.5" Rock

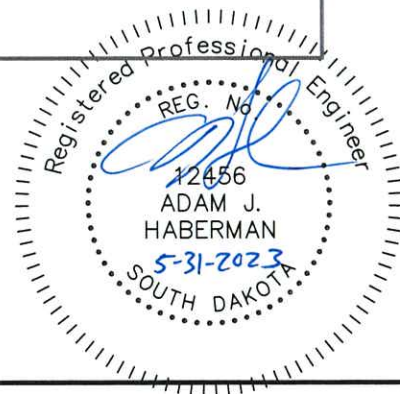

Silt Fence

Definition:

A temporary sediment barrier consisting of a filter fabric stretched across and attached to supporting posts and entrenched. The silt fence is a temporary linear barrier constructed of synthetic filter fabric and supported by wooden or steel posts.

Purposes:

- To intercept and detain small amounts of sediment from disturbed areas during construction operations in order to reduce sediment in runoff from leaving the site.
- To decrease the velocity of sheet flows and low-to-moderate level concentrated flows.

1. Set posts

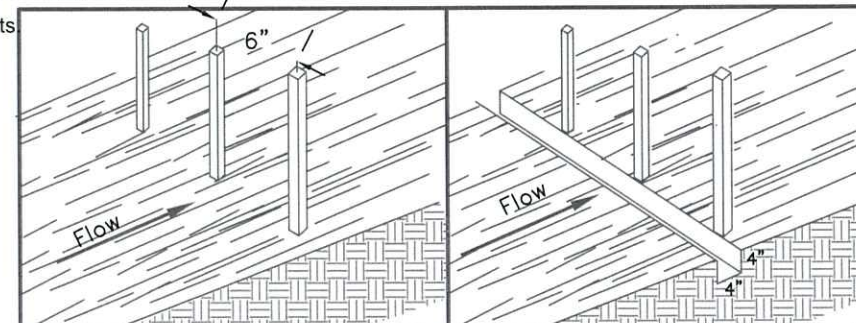

2. Excavate a 4" x 4" trench upslope along the posts.

3. Attach a supporting wire fence to the posts

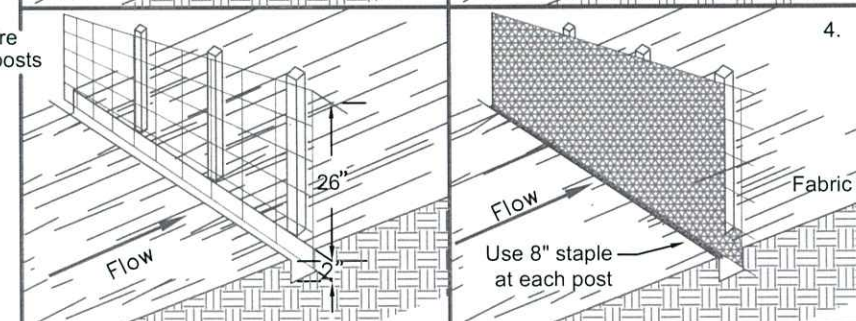

4. Attach fabric, sandwich fabric overlap between posts and wire and extend into trench.

Fabric to be 36" wide

5. Backfill trench. If rock type soils are encountered, utilize 30 to 40 lb sandbags butted end to end to prevent underflow.

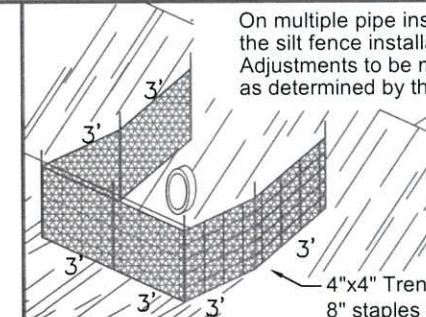
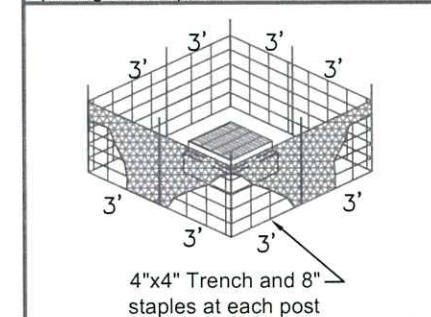
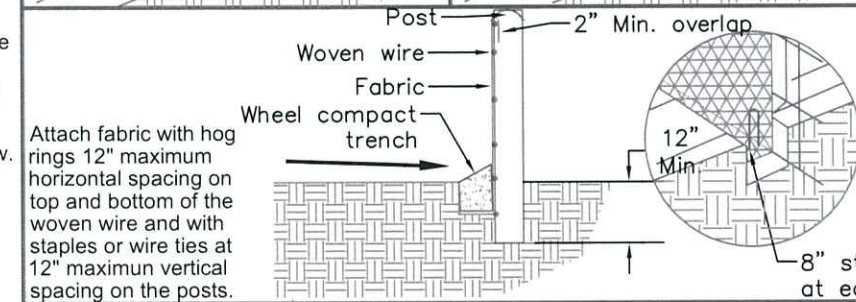

On multiple pipe installations, the width of the silt fence installation will increase. Adjustments to be made on the construction as determined by the engineer.

Fence material shall conform to geotextile specifications, Section 831 of SDDOT Standard Specifications for Roads and Bridges, latest edition.

Inlet Protection



Definition:

A sediment filter or an excavated impounding area around a storm drain drop inlet or curb inlet. To be used at sump conditions.

Purposes:

To reduce sediment from entering storm drainage systems prior to permanent stabilization of disturbed areas.

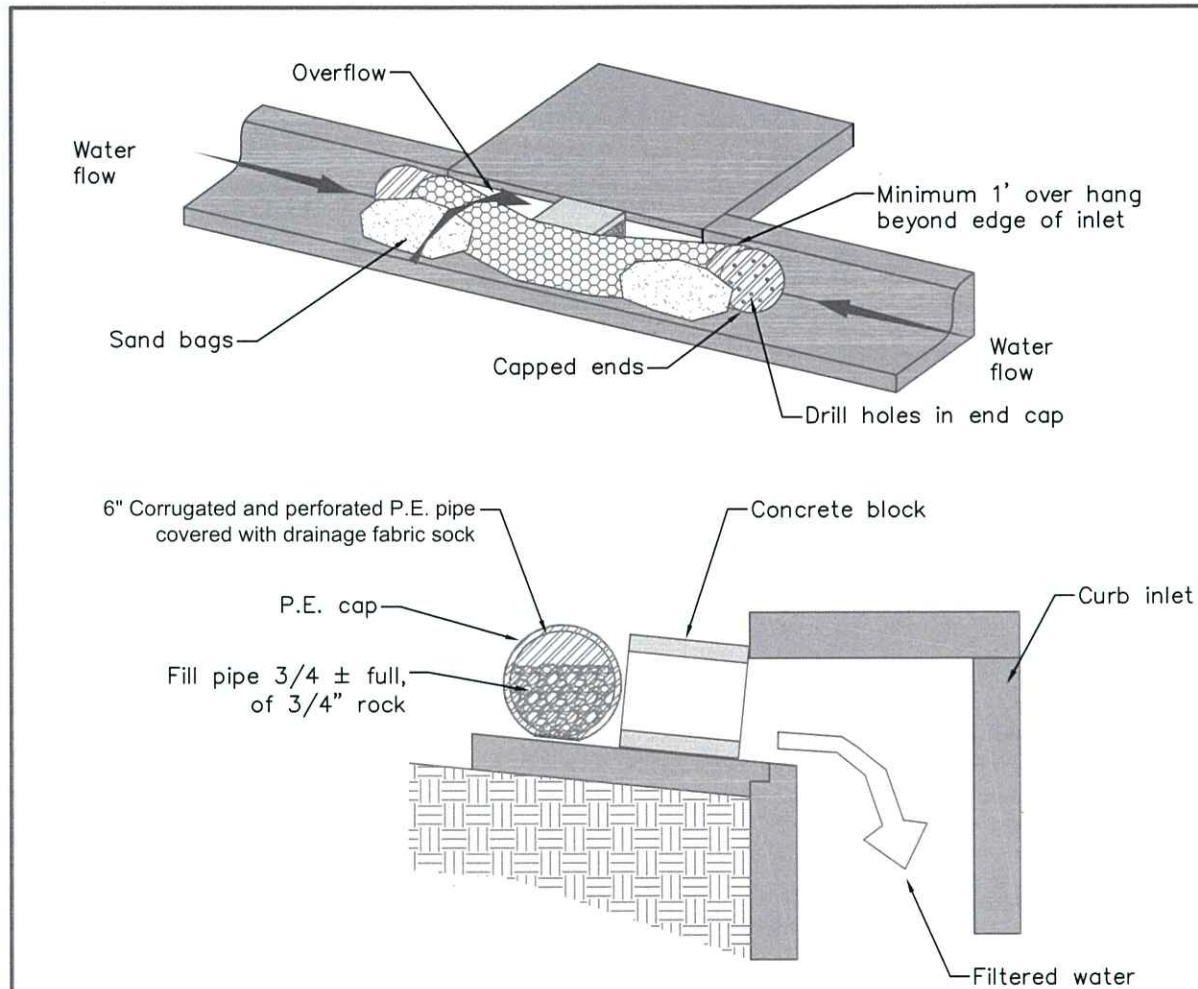

Specific Application:
 This method of inlet protection is applicable at curb inlets where ponding in front of the structure is not likely to cause inconvenience or damage to adjacent structures and unprotected areas. Clean out as necessary to prevent blockage of runoff conveyance.

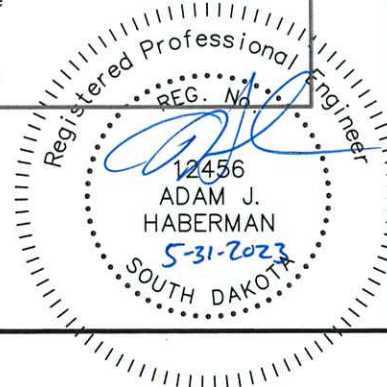

Inlet Protection



Definition:

A sediment filter or an excavated impounding area around a storm drain drop inlet or curb inlet.

Purposes:

To reduce sediment from entering storm drainage systems prior to permanent stabilization of disturbed areas.

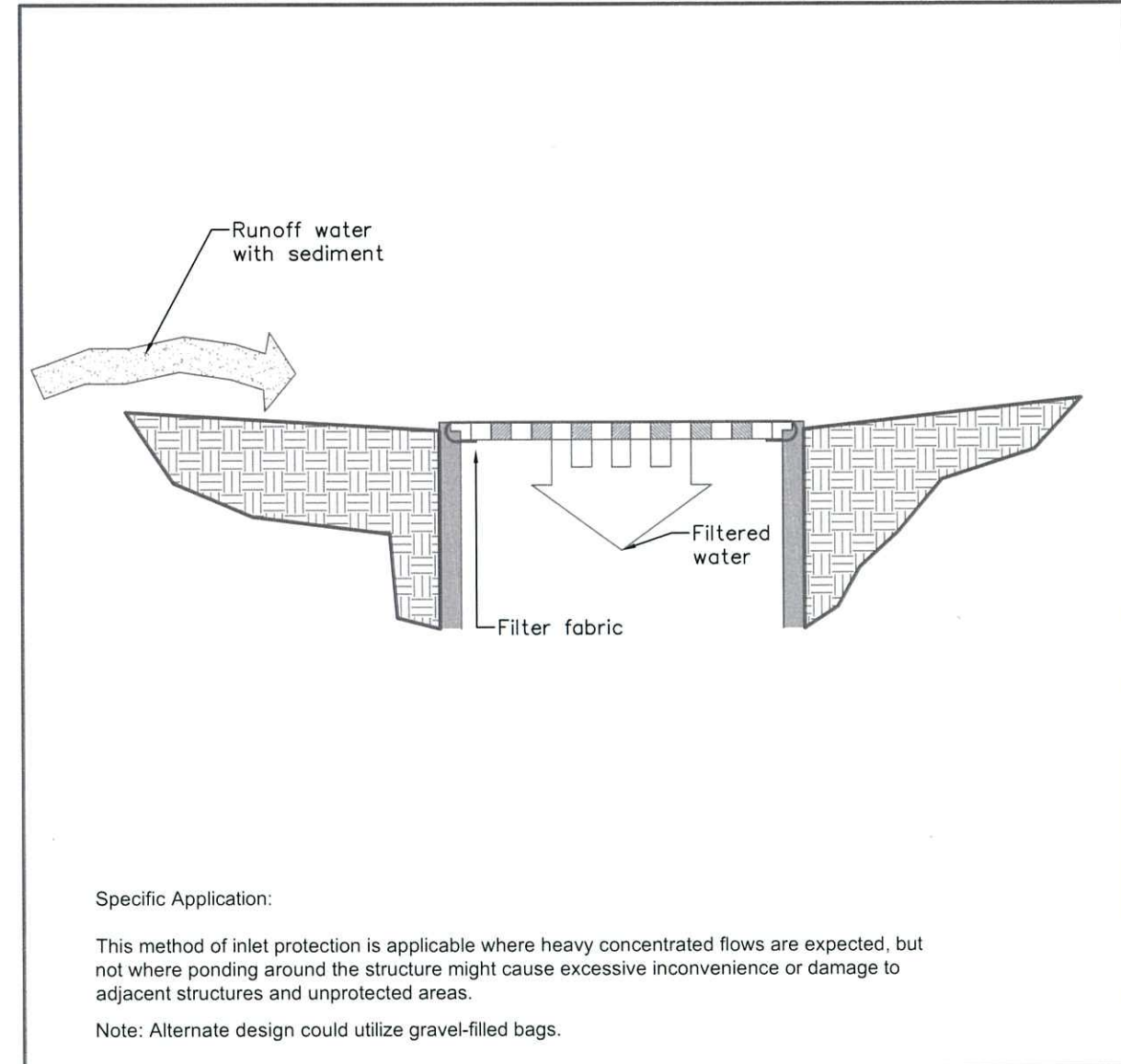

Specific Application:

This method of inlet protection is applicable where heavy concentrated flows are expected, but not where ponding around the structure might cause excessive inconvenience or damage to adjacent structures and unprotected areas.

Note: Alternate design could utilize gravel-filled bags.

Drainage and filtration fabric shall conform to Section 831 of SDDOT Standard Specifications for Roads and Bridges, latest edition.

REGION NO.	STATE OF	PROJECT	SHEET NO.	TOTAL SHEETS
8	S.D.	2023-011	36	39
X-SECTIONS 3RD ST				

3RD ST

1+50.00

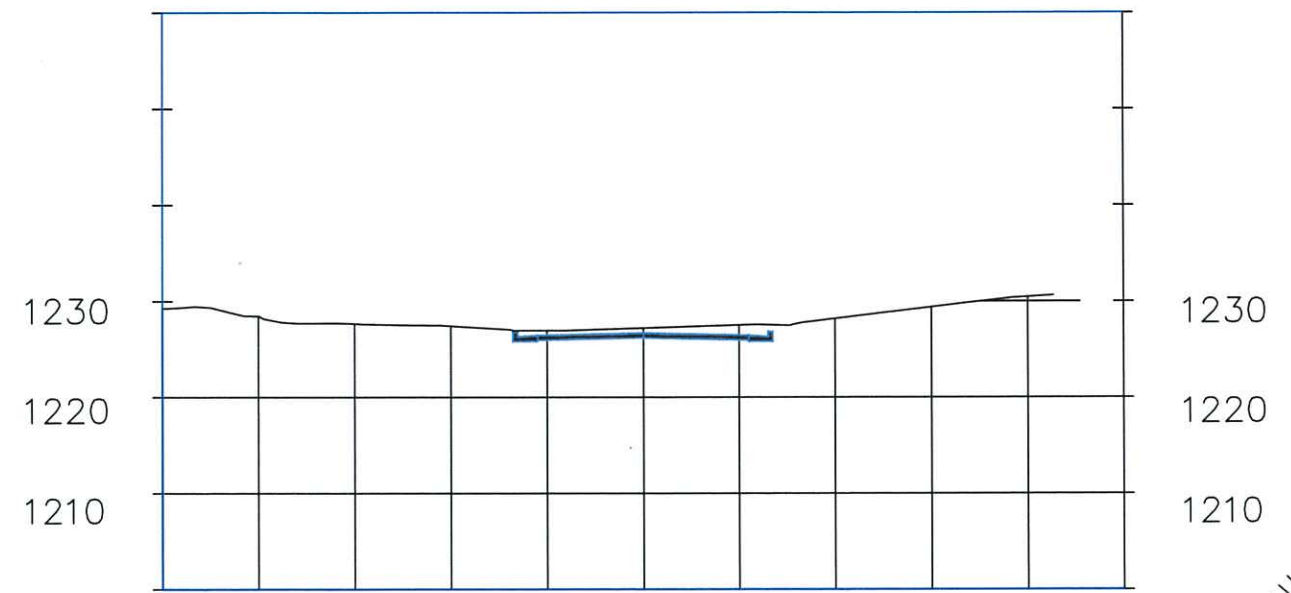

2+00.00

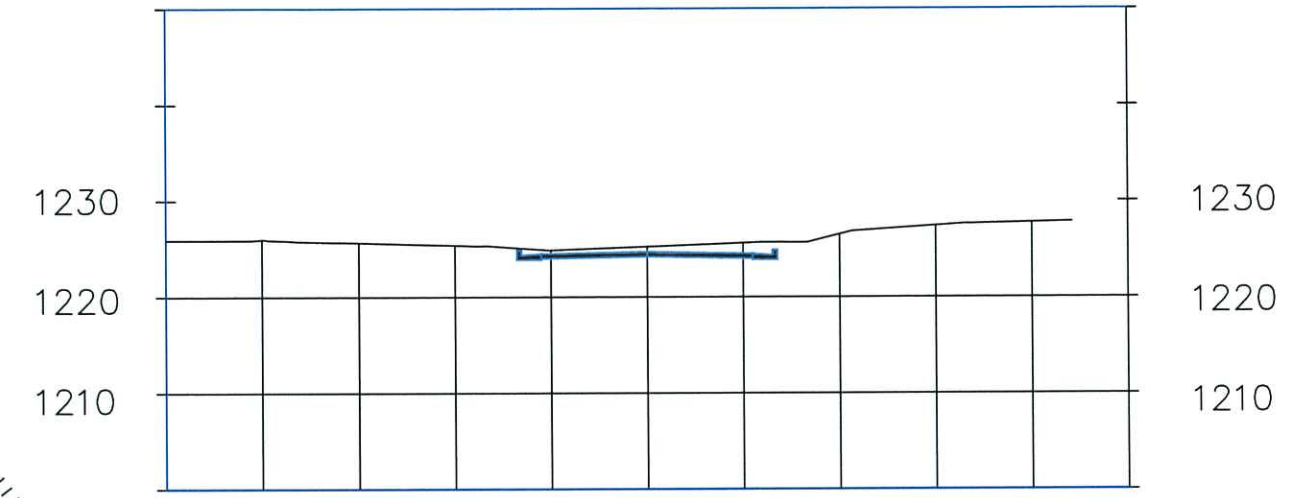

0+50.00

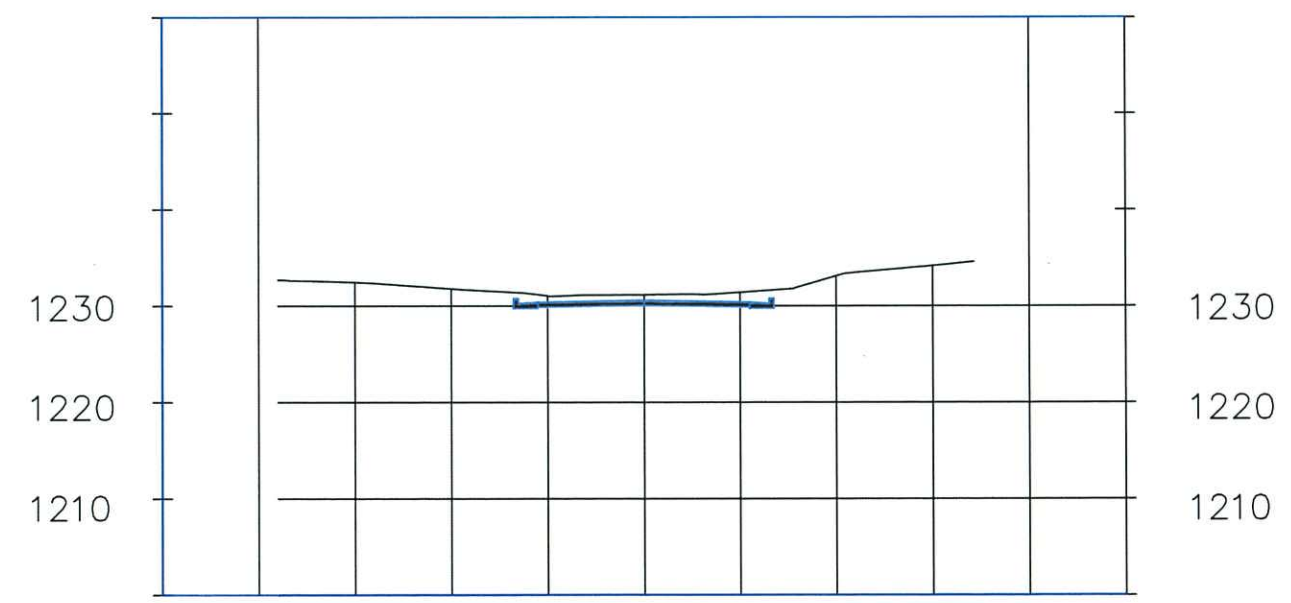

1+00.00

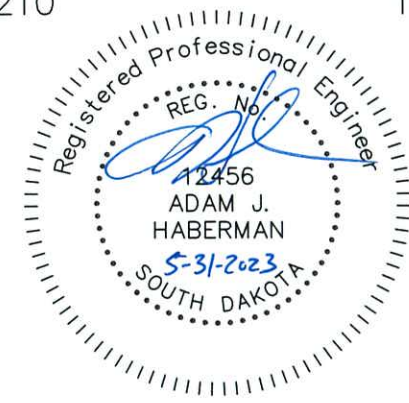
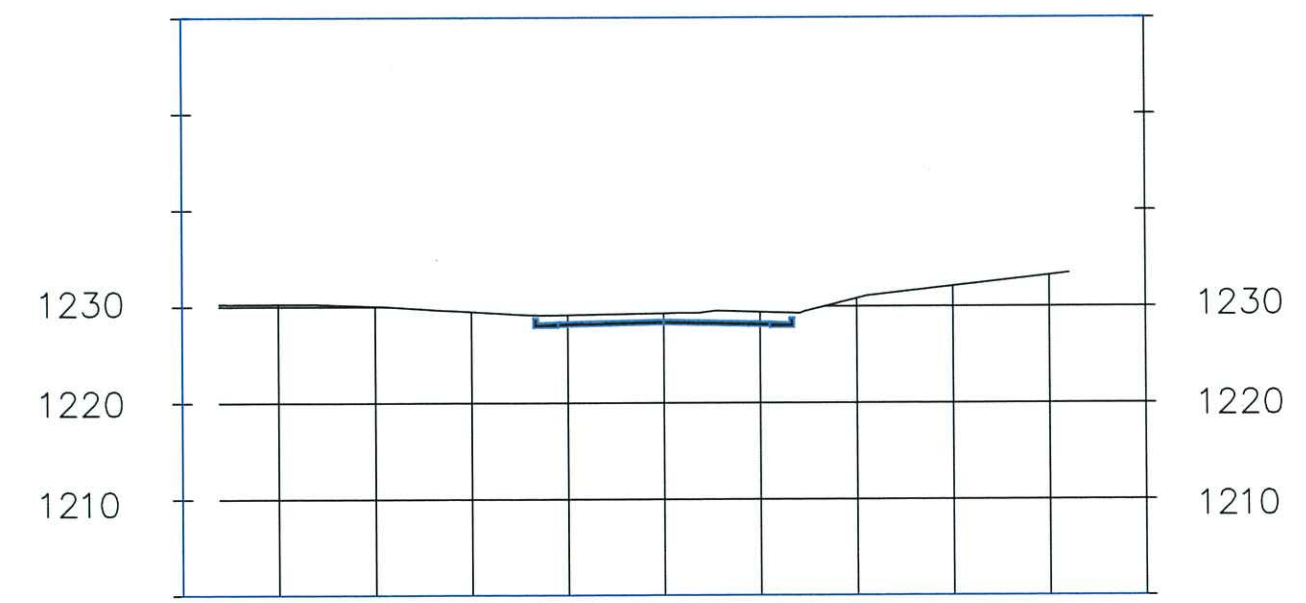

REGION NO.	STATE OF	PROJECT	SHEET NO.	TOTAL SHEETS
8	S.D.	2023-011	37	39
X-SECTIONS 3RD ST				

3+50.00



2+50.00

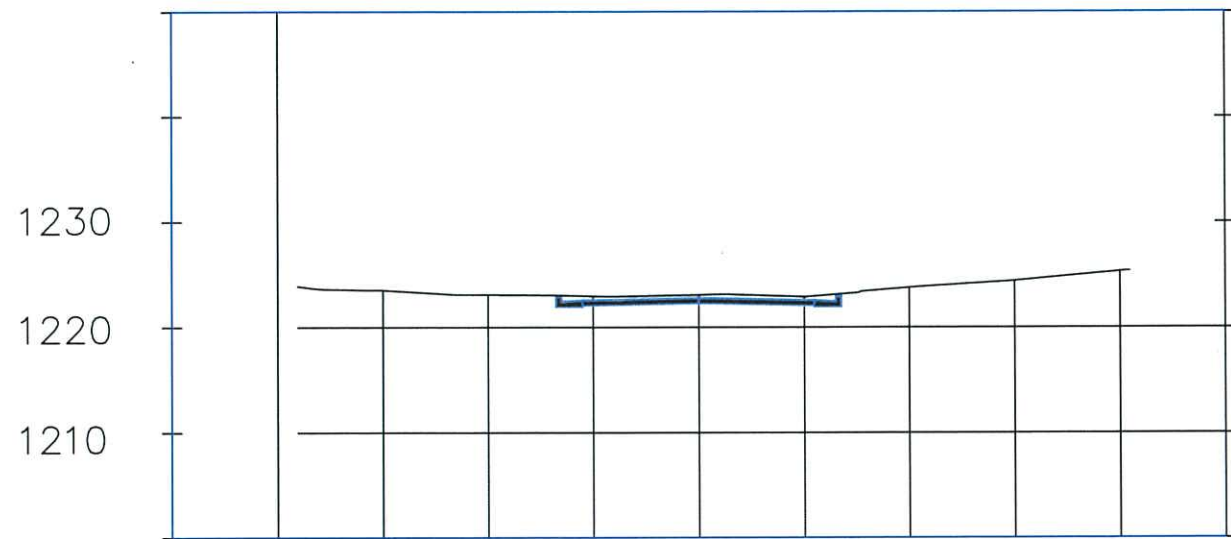

3+00.00

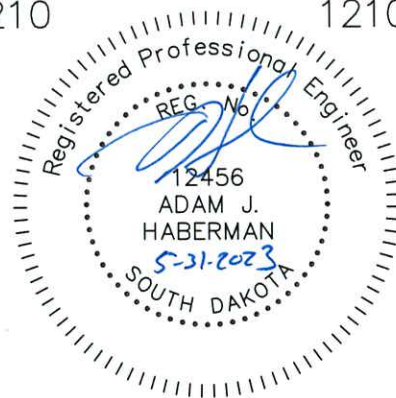
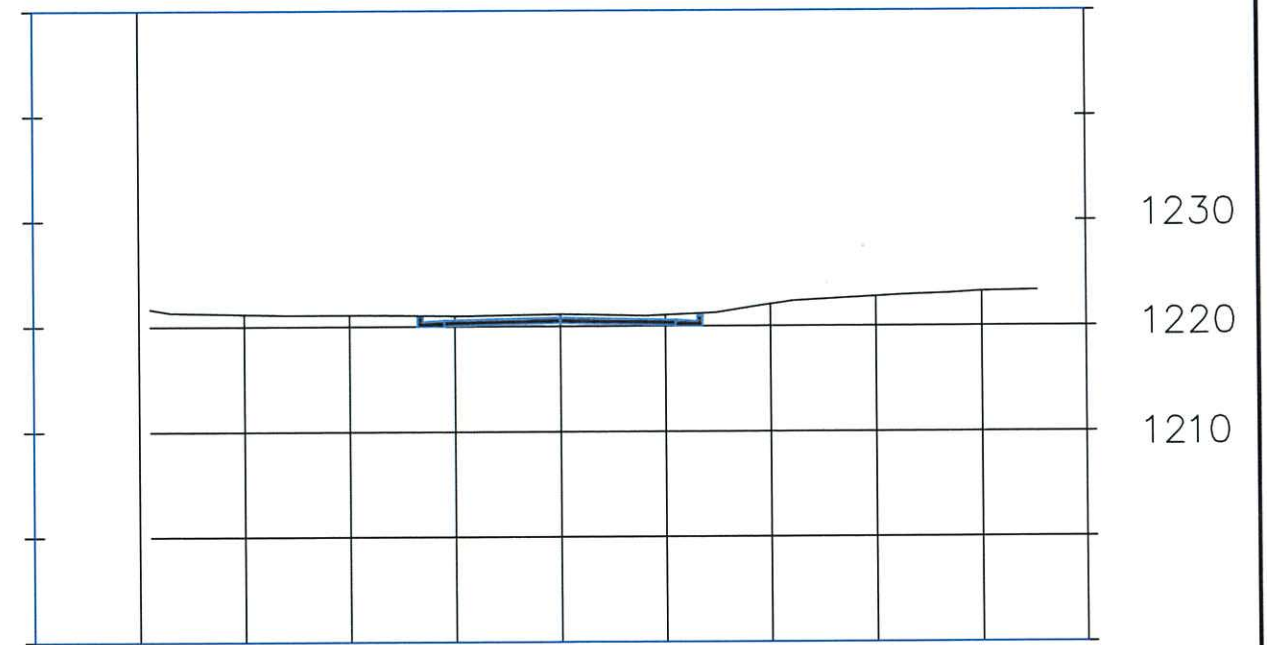

REGION NO.	STATE OF	PROJECT	SHEET NO.	TOTAL SHEETS
8	S.D.	2023-011	38	39
X-SECTIONS GREEN ST				

GREEN ST.

2+00.00

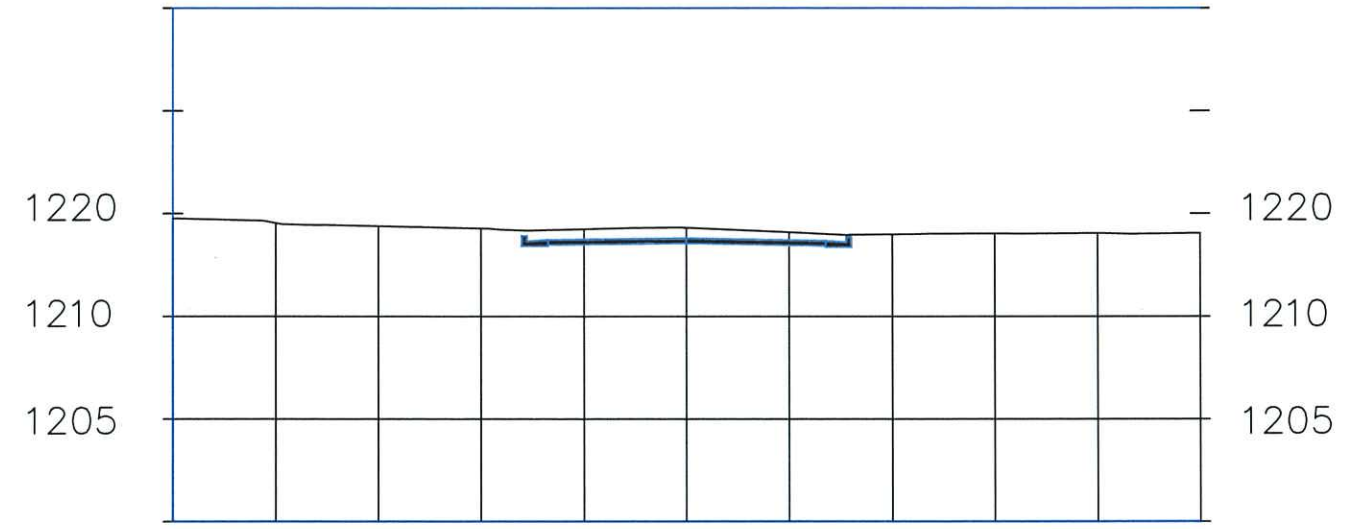

2+50.00

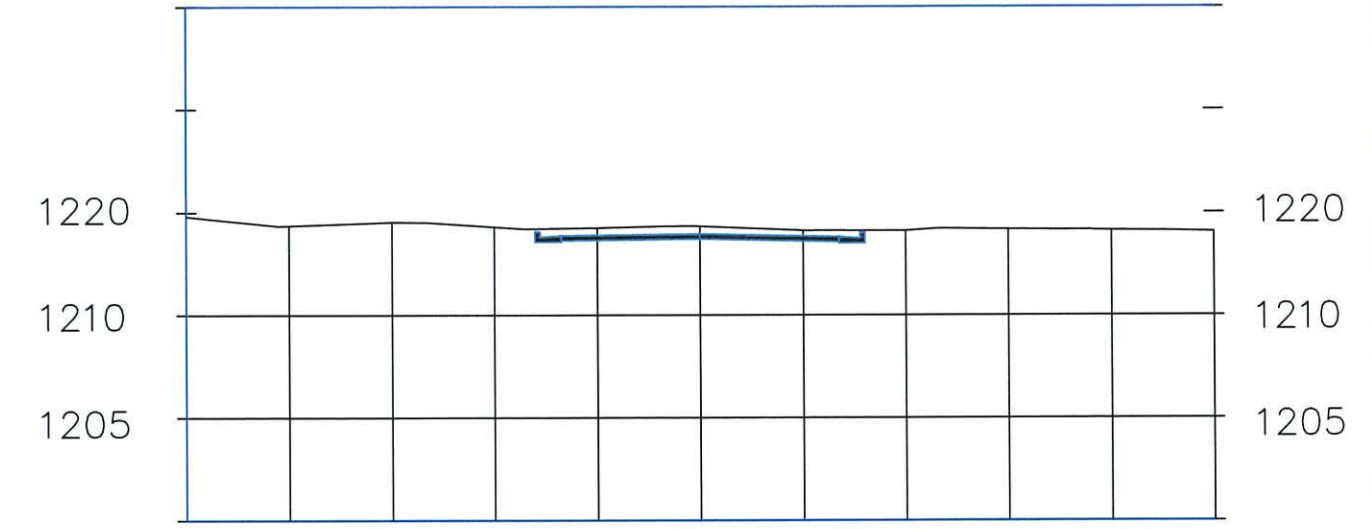

1+00.00

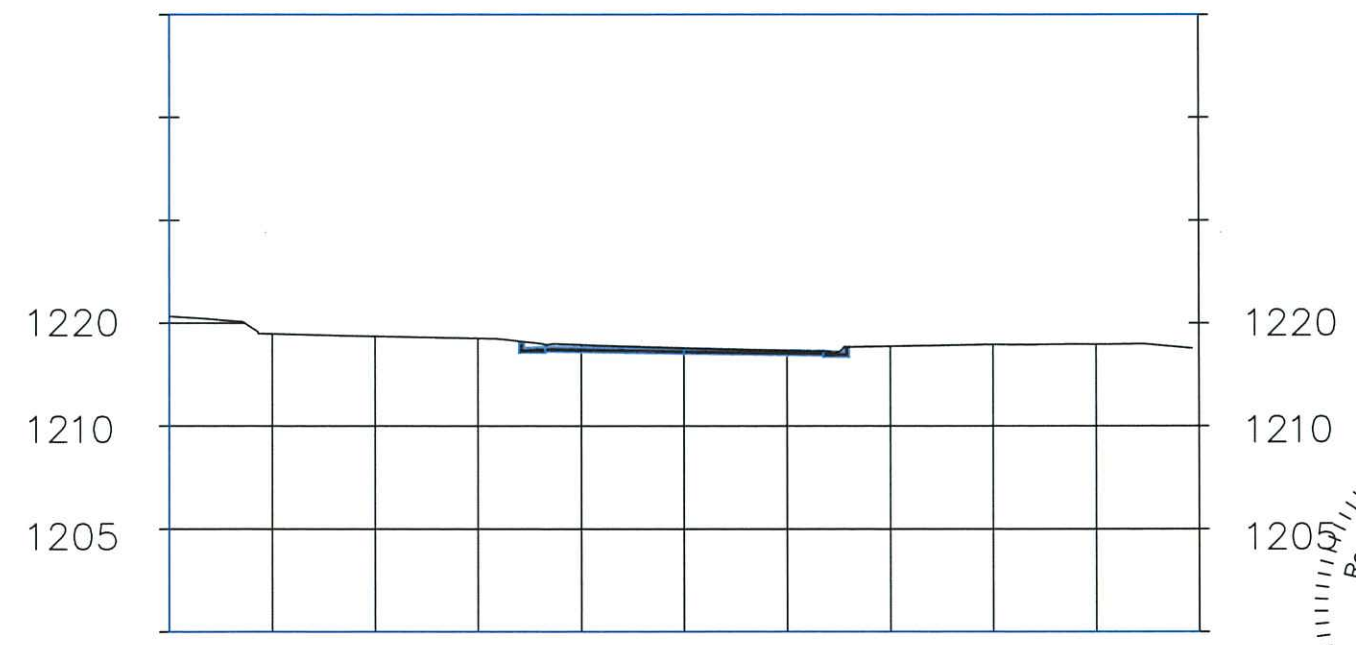

1+50.00

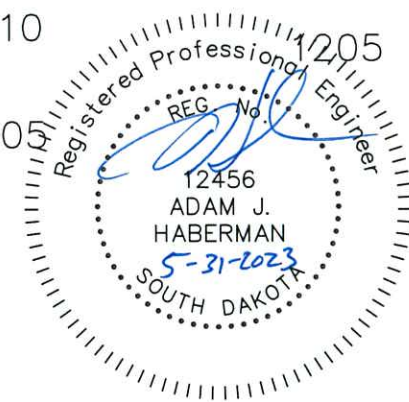
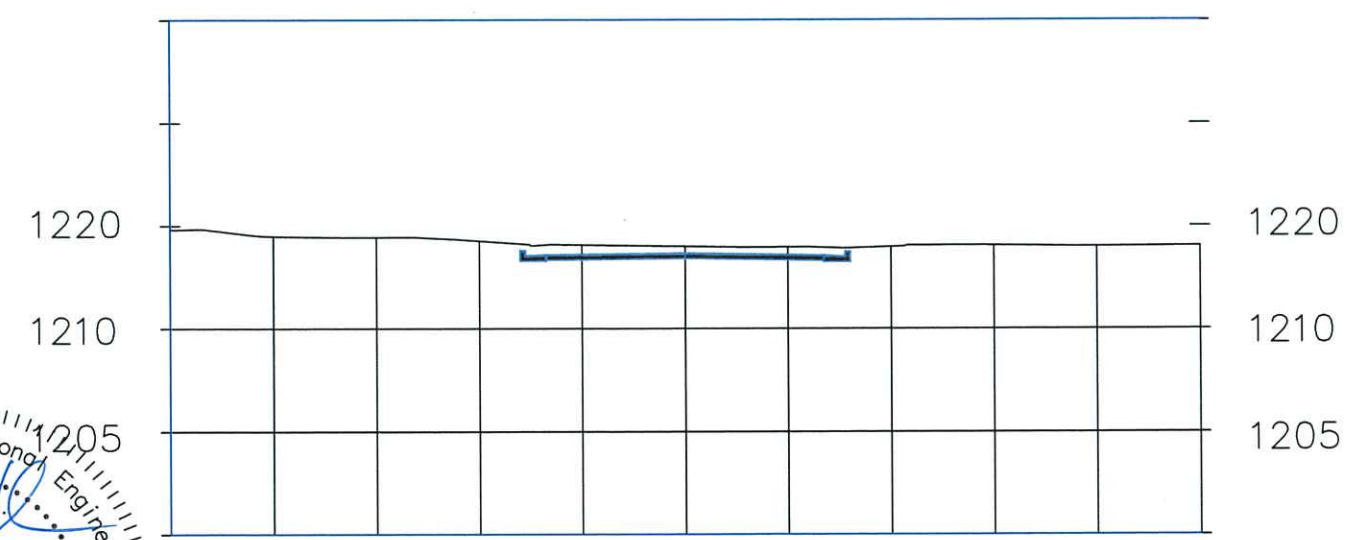

GREEN ST.

4+00.00

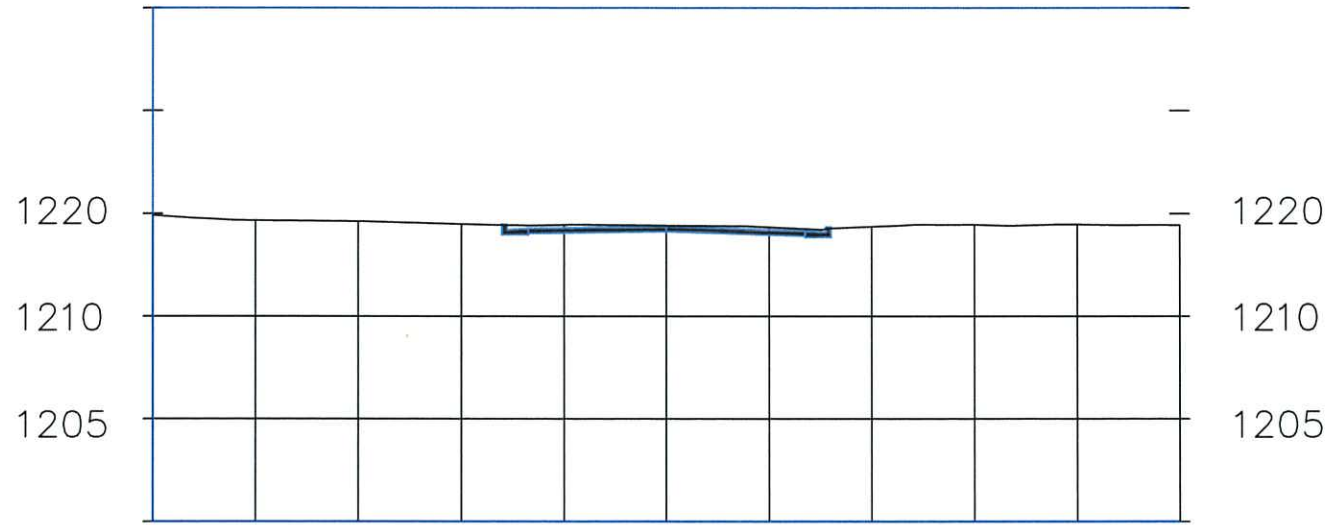

4+50.00

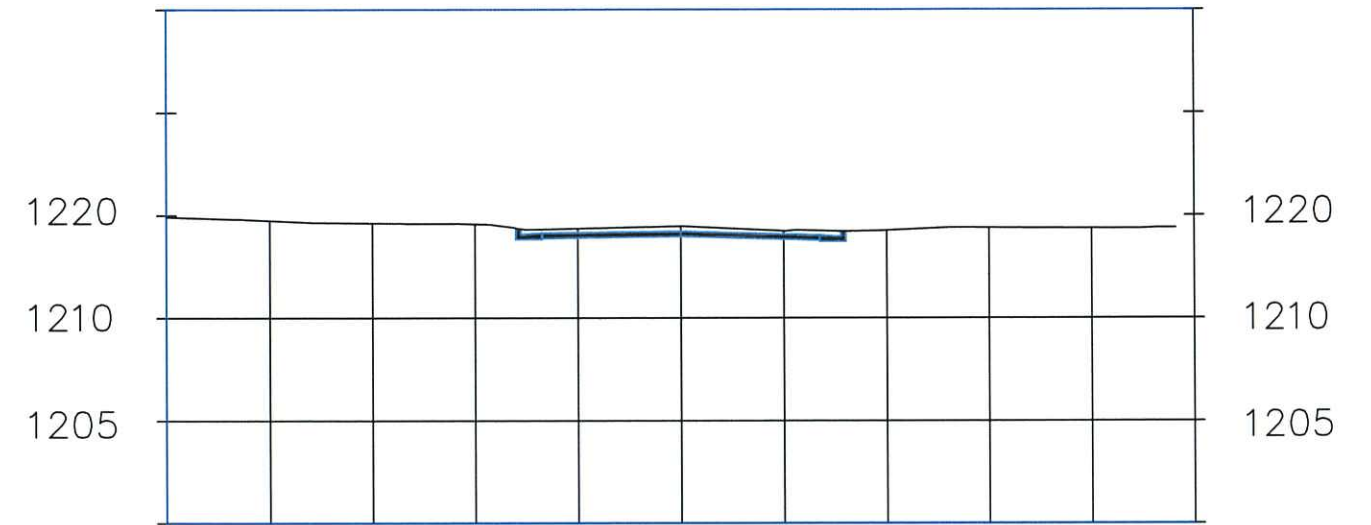

3+00.00

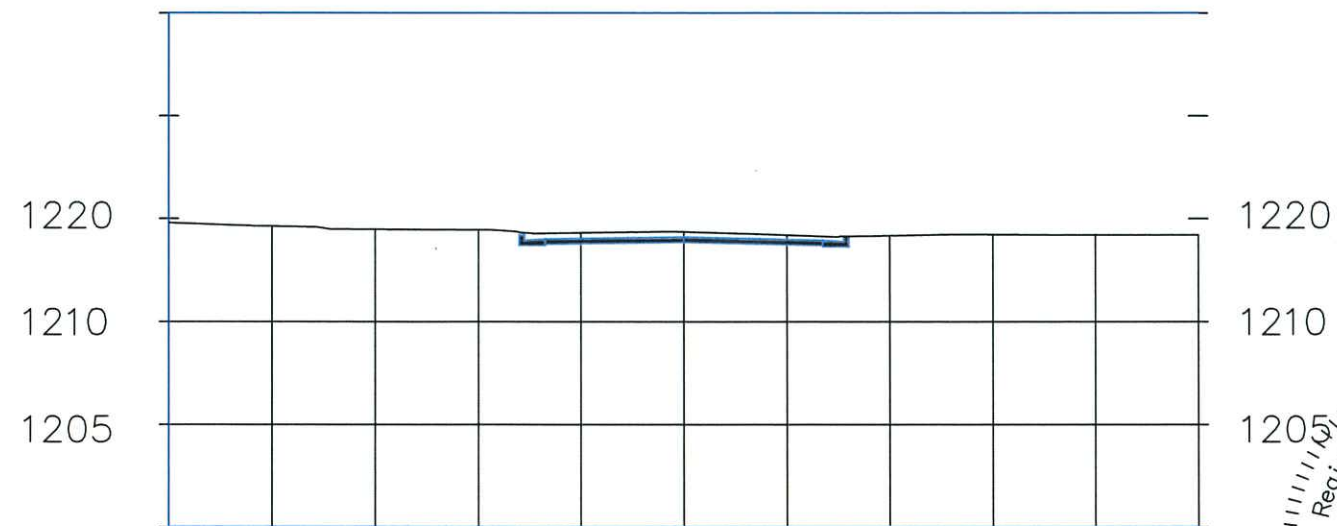

3+50.00

